



Education & Skills
Funding Agency

Building Bulletin 101

Guidelines on ventilation, thermal comfort and indoor air quality in schools

Version 1

August 2018

For technical professionals involved in the design, specification and construction of new school buildings and the refurbishment of existing buildings

Version control

Version	Amendments	Author/reviewer	Approved by	Date
V1		Richard Daniels Technical Manager, Education and Skills Funding Agency (ESFA)	Crawford Wright Head of Design, Education and Skills Funding Agency (ESFA)	1/08/2018

Foreword

This document sets out regulations, standards and guidance on ventilation, thermal comfort and indoor air quality for school buildings. It replaces Building Bulletin 101 (BB101), 'Ventilation of School Buildings', 2006.

We have updated the guidelines to align with the latest health and safety standards and industry practice. We have also strengthened the guidelines to improve thermal comfort and indoor air quality. This will improve school buildings and lead to healthier outcomes for students.

The guidelines on ventilation include:

- standards for all spaces including halls, classrooms and specialist practical areas such as science labs and design and technology spaces. Setting maximum levels of carbon dioxide in teaching spaces and minimum ventilation rates in practical spaces and specialist accommodation, eg for pupils with special needs.

The guidelines on thermal comfort include:

- guidance on room temperatures and cold draughts in order to provide a comfortable environment suitable for teaching and learning, year round.
- guidance on designing for children with disabilities who are less able to regulate their temperature than mainstream pupils.
- detailed calculation methods for thermal comfort. Adaptive thermal comfort calculations have been introduced to prevent summertime overheating based on the latest research on how people adapt to higher temperatures. These calculations use variable maximum indoor temperatures that depend on the outside temperature. This helps to avoid the unnecessary use of air conditioning by using passive measures such as night cooling and thermal mass to cool spaces in summertime.

The guidelines on indoor air quality include:

- a summary of the health effects of indoor air pollutants based on the World Health Organisation guidelines for Indoor Air Quality and the latest advice from Public Health England. This describes pollutant sources, both internally generated such as formaldehyde given off by furniture and external pollutants including nitrogen dioxide which are a major cause of concern for respiratory health.
- guidance on how to meet the maximum exposure levels for pollutants. Ways to reduce the level of outdoor air pollutants, such as Nitrogen Dioxide and Particulates from traffic, in the supply air. This includes the location of air intakes and exhausts, the management of openable windows, and filtration of supply air.
- advice on reducing sources of indoor pollutants, eg using materials that are low emitters of pollutants and dealing with pollutants generated by 3D printers and laser cutters.

Contents

Version control	2
Foreword	3
List of figures	7
List of tables	7
Summary	8
Expiry/review date	8
Who is this advice for?	8
Key points	8
Disclaimer	9
Acknowledgements	9
Glossary	11
1 Introduction	12
1.1 Indoor environmental quality	12
1.2 Ventilation strategy	14
1.2.1 Natural ventilation systems	14
1.2.2 Mechanical ventilation systems	14
1.2.3 Hybrid systems	14
2 Regulatory framework	17
2.1 Building Regulations	17
2.1.1 Part F of the Building Regulations on Ventilation	17
2.1.2 Part L on Conservation of Fuel and Power	18
2.1.3 Part C on Site Preparation, Contaminants, Moisture, Radon	18
2.1.4 Work on existing buildings	20
2.2 Health and safety legislation	21
2.3 School Premises and Workplace Regulations	21
2.4 DfE performance standards for teaching and learning spaces	23
2.4.1 Ventilation of practical spaces	24
2.5 Ventilation of other buildings and non-teaching spaces	25
2.6 Local extract ventilation	25
2.7 Indoor air quality and ventilation	26
2.8 Prevention of overheating in warmer weather	26
2.9 Gas safety regulations and standards	27
2.9.1 Gas interlocks	28
2.9.2 Gas safety interlocking by environmental/CO2 monitoring	31
2.9.3 Carbon monoxide, carbon dioxide and flammable gas detectors	31
3 Summary of regulations and guidance	34
4 Design	43
4.1 Ventilation strategy	43
4.2 Natural ventilation	43
4.2.1 Design of natural ventilation openings	45
4.2.2 Design of stack ventilation	45
4.3 Mechanical and hybrid ventilation	47
4.4 Location of ventilation air intakes and exhausts	48
4.4.1 Location of ventilation air intakes	48
4.4.2 Location of exhaust outlets	50
4.4.3 Exhaust of contaminated or polluted air and combustion products	51
4.5 Air quality	52
4.6 Filtration and air purification	53

4.7	The Coanda effect	53
4.8	Control of ventilation	54
4.9	Thermal comfort	55
4.9.1	Control of cold draughts	55
4.10	The effect of wind and rain	56
4.10.1	Testing of dampers and weather louvres	56
4.11	Building airtightness and thermal bridging	57
4.12	Window design	57
4.13	Thermal mass and night cooling	58
4.13.1	Requirements for exposed thermally massive building fabric	58
4.13.2	Thermal mass and night purge	59
4.14	Energy efficiency	60
4.15	Climate change adaptation	61
4.16	Heating system selection, sizing and control	62
4.17	Life cycle and maintenance	62
4.18	Acoustic standards	63
4.18.1	Indoor ambient noise levels	63
5	Ventilation for particular areas and activities	64
5.1	Office accommodation	64
5.2	Local extract ventilation	64
5.3	Atria, circulation spaces and corridors	66
5.4	Ventilation of practical spaces	67
5.5	Design and Technology	69
5.5.1	Laser cutters and 3-D printers	70
5.6	Food technology rooms	70
5.7	Science laboratories and fume cupboards	72
5.7.1	Design criteria	73
5.7.2	Bunsen burners	74
5.7.3	Fume cupboards	74
5.7.4	Preparation rooms	76
5.7.5	Chemical stores	76
5.7.6	Ventilation controls	76
5.7.7	Fume cupboard exhausts and building exhaust design	77
5.8	Local exhaust ventilation systems	78
5.9	Wood dust extract systems	81
5.9.1	Centralised systems	82
5.9.2	Local systems	83
5.9.3	Design of dust extract systems	83
5.10	ICT-rich teaching spaces	87
5.11	Sports halls and main halls	87
5.12	Ventilation in special schools and designated units	88
5.12.1	Infection control	89
5.12.2	Managing cross-infection	90
5.13	Catering kitchens	91
5.13.1	Grease filters and odour control	93
5.14	Dining areas	93
5.15	ICT Server rooms	93
6	Indoor and outdoor air quality	96
6.1	Indoor and outdoor air quality guidelines	96
6.2	Indoor air pollutants	99

6.3	Sources of indoor pollutants	102
6.4	Minimising sources	104
6.4.1	Indoor source control	104
6.5	Outdoor air pollutants and sources	107
6.5.1	Minimising ingress of polluted outdoor air into buildings	107
6.5.2	Filtration	109
6.5.3	Biomass boiler flues	111
7	Thermal comfort	112
7.1	Thermal comfort criteria	113
7.2	Operative temperature range	114
7.3	Local thermal discomfort from draughts	116
7.3.1	Natural ventilation systems	116
7.3.2	Forced draught systems	116
7.4	Radiant temperature difference	119
7.5	Underfloor heating	121
7.6	Performance standards for the avoidance of overheating	123
7.7	Assessment of performance in use	130
7.7.1	Performance in use standard for overheating	131
8	Design calculations for ventilation and thermal comfort	132
8.1	Internal conditions	132
8.2	Ventilation calculations	132
8.3	Ventilation Opening Areas	133
8.4	Mechanical ventilation	135
8.5	Thermal Comfort Calculations	136
8.5.1	Weather file for overheating risk assessment	136
8.5.2	Internal gains for overheating risk assessment	136
	Annex A: Carbon dioxide levels in schools	138
	Annex B: Indoor air pollutants, sources and health effects	143
	Annex C: Guidance on construction products and materials	150
	Annex D: Definition of opening areas	152
	References	155

List of figures

Figure 1-1 The Environmental Circle.....	12
Figure 1-2 Types of ventilation system.....	16
Figure 4-1 Examples of problematic flow patterns in a three storey atrium	45
Figure 4-2 Definition of the atrium enhancement metric.....	46
Figure 4-3 Ideal design blueprint for an atrium building.....	47
Figure 8-1 Example of ventilation area reduced by protrusion of window sill	135
Figure A-1 Typical changes in CO2 levels with demand control	139
Figure A-2 Average occupied CO2 concentration in February	140
Figure A-3 Average occupied CO2 concentration in July	140
Figure A-4 A Secondary School all year CO2 monitored results	141
Figure A-5 Wintertime CO2 levels monitored	141

List of tables

Table 2-1 Summary of interlock requirements according to appliance type.	30
Table 3-1 Summary of Regulations and guidance	34
Table 4-1 Ventilation intake placement to minimise pollutant ingress	49
Table 5-1 Recommended minimum local extract ventilation rates	65
Table 5-2 Minimum exhaust rates for science and practical spaces	68
Table 5-3 Fume Ventilation Systems.....	70
Table 5-4 Types of dust extraction	85
Table 5-5 Environmental standards for sports halls	88
Table 5-6 Ventilation for special educational needs and special schools	90
Table 6-1 WHO IAQ guidelines and UK ambient air quality standards.....	98
Table 6-2 SINPHONIE indicators for IAQ monitoring in European schools.....	99
Table 6-3 Typical sources of indoor air pollutants in school buildings	103
Table 6-4 Building materials, product labels on chemical emissions in EU	106
Table 6-5 Recommended minimum filter classes (from BS EN 13779).....	110
Table 7-1 Categories of space or activity	113
Table 7-2 Recommended operative temperatures during the heating season	115
Table 7-3 Comfort categories for cold draughts	117
Table 7-4 Draught criteria for mechanical ventilation systems	118
Table 7-5 Radiant Temperature Asymmetry, RTA = 7K.....	120
Table 7-6 Radiant Temperature Asymmetry, RTA = 5K.....	120
Table 7-7 Categories applying to underfloor heating.....	122
Table 7-8 Adaptive thermal comfort category to apply	126
Table 7-9 Categories for overheating risk assessment	127
Table B-0-1 Indoor air pollutants, sources and health effects	143

Summary

Section 1 provides an introduction and describes the factors that affect the design of the indoor environment of schools.

Section 2 describes the regulatory framework for schools in full. It gives the recommended Department for Education (DfE) performance standards for compliance with UK regulations.

Section 3, table 3-1 is a quick reference guide showing which parts of BB101 are regulatory, which are ESFA recommended design standards, and which are for further information and guidance. The regulatory standards are covered in section 2. The ESFA recommended design standards are also in the ESFA Output Specification: Generic Design Brief and Technical Annexes, in particular Technical Annex 2F: 'Mechanical services and public health engineering', published in 2017.

Sections 4 is an overview for the whole design team.

Sections 5 to 8 provide non-statutory guidance on how to design schools to achieve adequate performance for ventilation, indoor air quality and thermal comfort.

Expiry/review date

This advice will be reviewed in 2022.

Who is this advice for?

This advice is for those involved in the design, specification and construction of new school buildings and the refurbishment of existing buildings. This may include:

- contractors
- architects
- engineers
- project managers
- building users
- facilities managers
- governors
- parents
- students

Key points

This document is guidance on the design and construction of schools. It advises on good indoor air quality and thermal conditions that help to create effective teaching and learning spaces.

It covers normal occupation and does not cover emergency situations for example ventilation for smoke clearance.

Disclaimer

The department and its advisers accept no liability for any expense, loss, claim or proceedings caused by reliance on this guidance.

Acknowledgements

The DfE would like to thank the following organisations for their help in drafting this document:

The Chartered Institution of Building Services Engineers (CIBSE)
CLEAPSS
The Design and Technology Association (DATA)
The Health and Safety Executive
The Institution of Gas Engineers and Managers (IGEM)
The Institute of Local Exhaust Ventilation (ILEV)
Public Health England

The DfE would also like to thank the following reviewers and members of the BB101 advisory group:

David Bradbury, Lars Fabricius, SAV
Ken Bromley, Department for Communities and Local Government (DCLG)
Barrie Church, IGEM
David Coley, University of Bath
Owen Connick, Breathing Buildings
Malcolm Cook, Loughborough University
Guy Channer, Dominic Cropper, Arup
Sani Dimitroulopoulou, Public Health England
Peter Dymont, Camfil
Matt Endean, Dave Parry, CLEAPSS
Mike Entwistle, Peter Henshaw, Buro Happold
Shaun Fitzgerald, Breathing Buildings and Cambridge University
Alan Fogarty, Robin Pritchett, Paul Sperring, Cundall
Wally Gilder, ILEV
James Hammick, Passivent
Nick Hopper, Monodraught
Chris Iddon, SE Controls
Benjamin Jones, University of Nottingham
Roy Jones, Gilberts
Keeran Jugdoyal, Tim Taylor, Dane Virk, Alastair Rowe, Stephen McLoughlin, Faithful & Gould/Atkins
Paul Keepins, Welsh Government
Jackie Maginnis, Modular and Portable Buildings Association
Laura Mansel-Thomas, Chris Brown, Ingleton Wood

Graham McKay, IGEM
Azadeh Montazami, Coventry University
Gary Morgan, Eco-Airvent
Malcolm Orme, Aecom
Hershil Patel, Jacobs
Paul Cooper, Hoare Lea
Paul Vorster, Van Zyl de Villiers
Peter Rankin, DCLG
Jannick Roth, Windowmaster
Ricardas Ruikis, Airflow Developments
Andrew Spencer, Richard Daniels, ESFA Engineering Design
David Tomkin, IGEM
James Vaux-Anderson, Bowmer and Kirkland
Craig Wheatley, IES
James Wheeler, HSE
Phillip Wild, IGEM, CoGDEM, Duomo

Glossary

Natural ventilation is where the driving force for the supply of fresh air and extract of stale air is buoyancy or wind.

Mechanical ventilation is where the driving force for the supply of fresh air and/or extract of stale air is provided by a fan.

Mixed mode and **hybrid ventilation** are ventilation systems that combine or switch between natural and mechanical ventilation and/or cooling systems.¹

The term **average** in this document means the arithmetic mean.

Kelvin is the absolute temperature scale, ie 20°C = 293 K. The convention is to use degrees K to show temperature differences.

Operative temperature is sometimes known as “dry resultant temperature”; it takes account of the mean radiant temperatures of the surfaces in the room and the air temperature in the room.

PPD is Percentage People Dissatisfied and is used in comfort criteria.

PMV is Predicted mean vote and is also used in comfort criteria.

The working definition of **overheating** used in this document is derived from the definition used by the Zero Carbon Hub for homes:

‘The phenomenon of excessive or prolonged high temperatures, resulting from internal or external heat gains, which may have adverse effects on comfort, health or learning activities’²

A **Free Running** building is not actively heated or cooled and may have either natural or mechanical ventilation. Most schools are free running outside the heating season.

For definitions of building services terms such as radiant temperature, see CIBSE Guide A.

The **heating season** is defined as the period when the heating system is normally switched on. It is defined as from 1 October to 30 April.

The **clo** is a measure of the thermal insulation of clothing. 1 Clo = 0.155 m²K/W

¹ ‘AM10: Natural Ventilation in Non-Domestic Buildings’, CIBSE, September 2005 gives more information on mechanical, natural, hybrid and mixed mode ventilation online at the [CIBSE website](#)

² ‘Overheating in homes the big picture’, The Zero Carbon Hub, June 2015, online at [the zero carbon hub website](#)

1 Introduction

1.1 Indoor environmental quality

Ventilation is a key part of holistic design for Indoor Environmental Quality (IEQ). The environmental circle describes the design factors³ that need to be addressed and the potential conflicts that need to be resolved.⁴

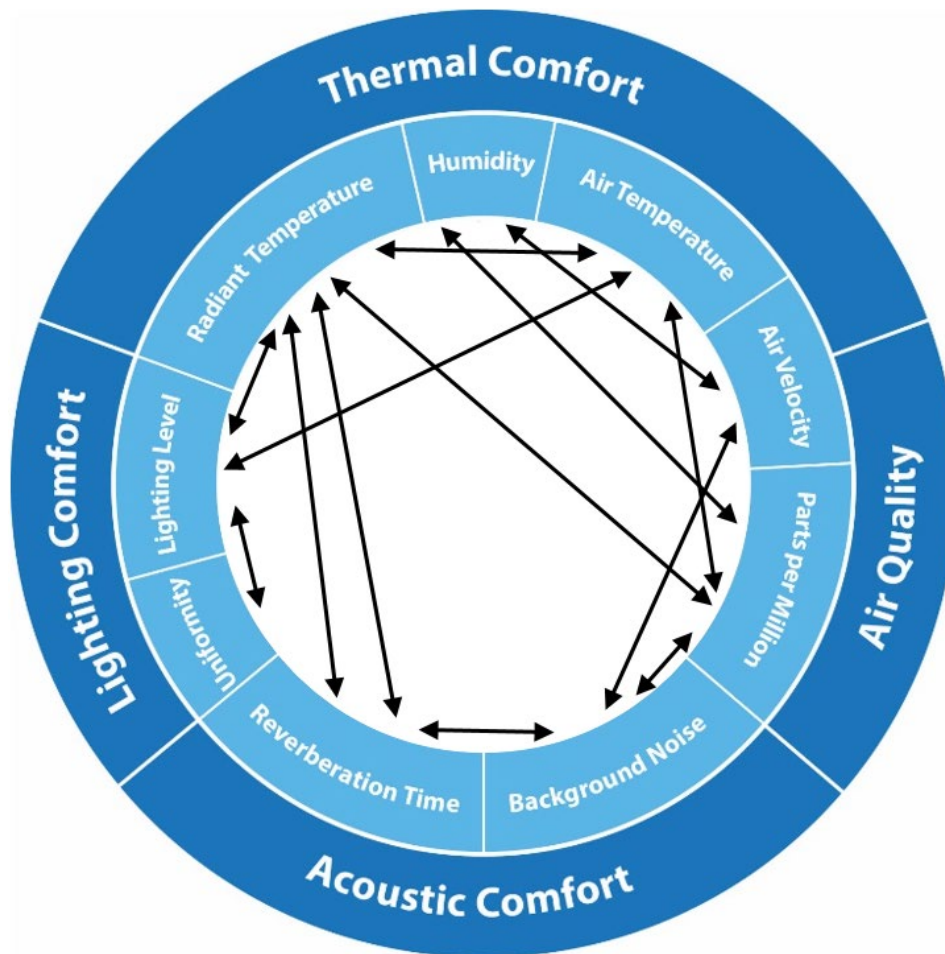

Figure 1-1 The Environmental Circle

Building Bulletin 93 'Acoustic Design of Schools: Performance Standards', Department for Education, 2015 and , 'Acoustics of Schools: a design guide', published by the

³ Montazami, Azadeh, Mark Gaterell, and Fergus Nicol. "A comprehensive review of environmental design in UK schools: History, conflicts and solutions." *Renewable and Sustainable Energy Reviews* 46, (2015): 249-264.

⁴ 'TM57: Integrated School Design', 2015 online at [CIBSE](#), contains a discussion of some of the design conflicts and ideas to resolve them.

Institute of Acoustics and the Association of Noise Consultants, November 2015 give the design criteria for acoustics and guidance on how to meet them.⁵

CIBSE Lighting Guide LG5, 'Lighting in Education' gives the criteria for lighting design in schools.⁶ Technical Annex 2E: 'Daylight and electric lighting' and Technical Annex 2C: 'External Fabric', to the Education Funding Agency (ESFA) Output Specification: Generic Design Brief, provide detailed specifications for ESFA delivered projects. See also ESFA guidance on baseline designs.⁷

A holistic, multi-disciplinary approach prevents unintended consequences of design driven by low energy or other overarching design drivers.⁸

The overarching factors that influence the design include:

- the adaptability of the building to changes in occupants' needs, changes in outside noise levels and pollution, and future climate change
- the use and maintenance of the building and its technologies
- low energy performance
- life cycle and operational running costs
- sustainability

As well as the environmental design factors, the building occupants and facilities management team should be considered. For example:

- the facilities management team need to understand the building environmental systems and controls
- the staff need to understand the basic building operation and occupant controls
- the designers need to understand the occupants' needs and their behaviour in use of the space

Examples of occupants' needs that affect the design are:

- perceptions of thermal, visual and acoustic comfort
- movement between teaching spaces
- impact of external canopies providing sheltered areas for early years on ventilation and daylight
- movement between the inside and outside in early years
- adequate wall area left clear for display

⁵ See References section, Refs. 3 and 4.

⁶ Lighting Guide 5 (LG5), 'Lighting in Education', October 2011, online at [CIBSE](#)

⁷ 'Baseline designs for schools: guidance', Education Funding Agency, May 2014, online at [GOV.UK](#)

⁸ 'International Performance Measurement & Verification Protocol, Concepts and Practices for Improved Indoor Environmental Quality, Volume II, Revised March 2002, DOE/GO-102002-1517', International Performance Measurement & Verification Protocol Committee online at [the ipmvp website](#)

The success or failure of the design also depends on the handover of the systems to the facilities management team and to the staff. The Soft Landings approach⁹ helps greatly and post occupancy Building Performance Evaluation (BPE)¹⁰ provides the necessary feedback into the specification of future design criteria.

1.2 Ventilation strategy

There are a range of ventilation strategies that can be adopted to meet the design requirements, see figure 1-2. These range from a completely natural system to a completely mechanical system. For classrooms and practical spaces in a school, the constraints of the design will determine the ventilation strategy that can be used. In the majority of current designs, the general teaching spaces use hybrid or mixed mode systems that make use of a mixture of mechanical and natural ventilation.

1.2.1 Natural ventilation systems

The driving force for these systems is the wind and the stack effect. This includes single sided ventilation, cross ventilation or stack ventilation systems. They can involve:

- opening windows (can be manual, automated, or a combination of both)
- opening dampers (can be manual, automated, or a combination of both)
- roof stacks (these can be manual or automated, but automated ones are more common)

1.2.2 Mechanical ventilation systems

These systems are fan driven. There are two types:

- centralized systems which have supply and extract.
- room-based systems which have supply and extract.

1.2.3 Hybrid systems

These systems use both natural driving forces of the wind and the stack effect and fans to supplement these driving forces. A hybrid system is operating in mechanical mode when the driving force for ventilation is a fan.

⁹ See information online at the [Government Soft Landings](#) website.

¹⁰ For information on the ESFA's BPE methodology for schools, See ESFA: Output Specification, Generic Design Brief, 2017, section 2.15.

These types of system use natural ventilation components with systems such as:

- fans to aid mixing in colder weather
- fans to aid higher flow rate in hotter weather
- a mechanical ventilation system which works in tandem (at the same time) as the natural ventilation system in colder weather
- a mixed mode system with a mechanical ventilation system which works when the natural ventilation system does not (for example systems that turn off in warmer weather when opening windows are used)
- a mechanical ventilation system which works when the natural ventilation system does not, and also works in tandem with the natural ventilation components

Figure 1-2 Types of ventilation system

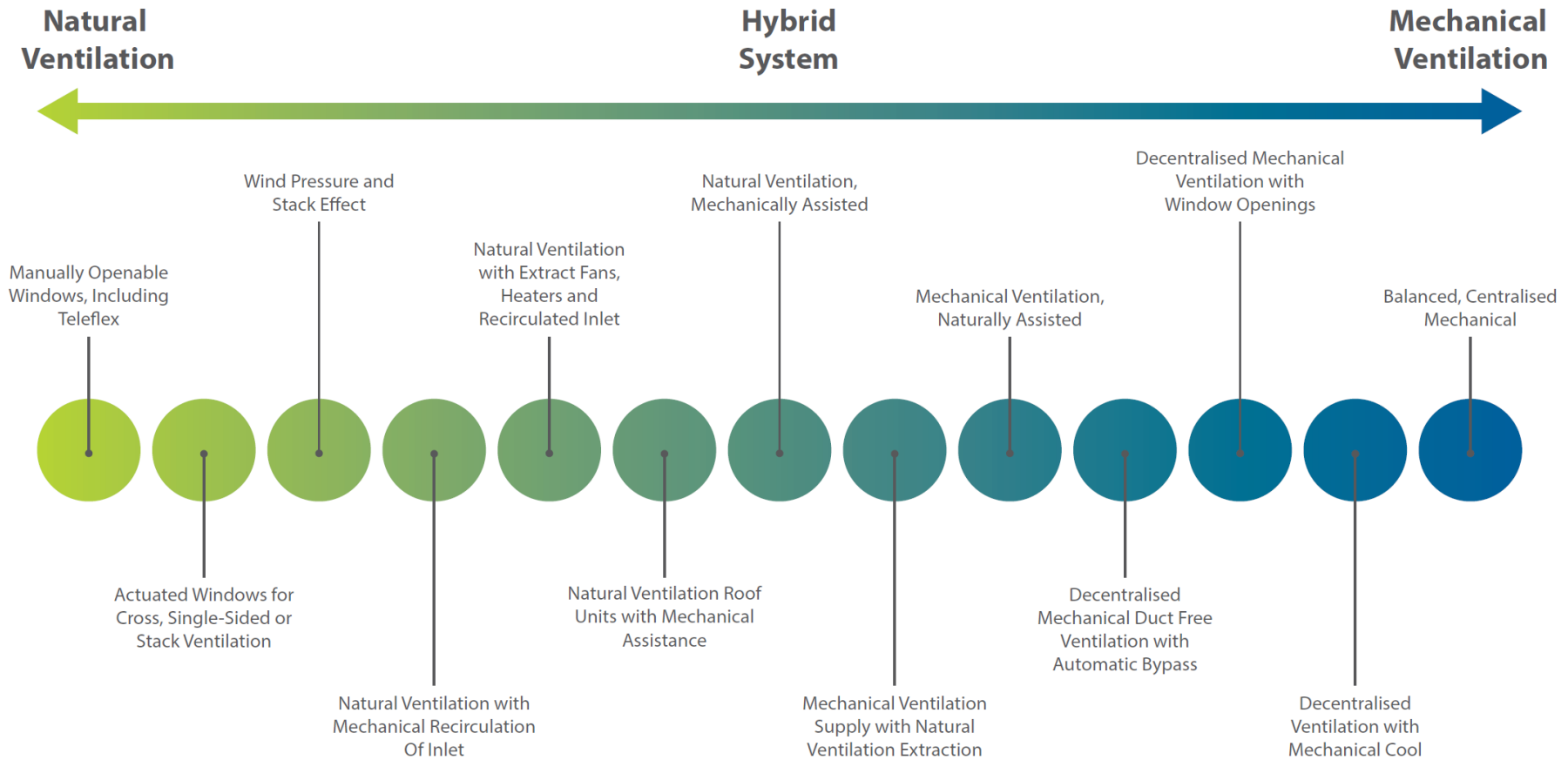

2 Regulatory framework

This section gives an overview of the regulations that relate to ventilation, thermal comfort and indoor air quality in schools.

2.1 Building Regulations

The UK Building Regulations contain functional requirements (called standards in Scotland); including the requirement that buildings must be adequately ventilated for people.

These functional requirements are drafted in broad terms. The government issues documents providing practical guidance on ways to comply in more common building situations. These are called Approved Documents (ADs) in England and Wales, Technical Handbooks in Scotland and Technical Booklets in Northern Ireland. They are not intended to be comprehensive and so may contain references to other documents, which provide extra guidance.

BB101 is one of those extra documents, with guidance on ventilating schools that adds to the guidance on ventilating buildings in AD F (in England) or the Non-Domestic Technical Handbook (in Scotland), and Technical Booklet K (in Wales). Note that following the guidance in an AD, Technical Handbook or Technical Booklet does not guarantee compliance with Building Regulations, but there is a legal presumption of compliance.

The requirements of Building Regulations can differ between England, Wales, Scotland and Northern Ireland. The following sections describe the requirements in England but in the devolved administrations only where they differ.

2.1.1 Part F of the Building Regulations on Ventilation

Part F of the Building Regulations applies to buildings including schools. Requirement F1(1), from Part F of Schedule 1 to The Building Regulations 2010, states:

“There shall be adequate means of ventilation provided for people in the building.”

Guidance showing ways of complying with requirement F1 is contained in AD F.¹¹ For guidance on schools, AD F refers to BB101. AD F makes no

¹¹ ‘Approved Document F: Means of Ventilation’, The Building Regulations, 2010, online at www.GOV.UK

provision for ventilation with the specific aim of controlling or reducing the risk of summertime overheating.

2.1.2 Part L on Conservation of Fuel and Power

The criteria for limiting heat gains (cf. Criterion 3 and the BRUKL method) used in Approved Document L2A (AD L2A), 2013 edition, sets out an approach to limiting heat gains in buildings as required by paragraph L1(a)(i) of Schedule 1 to the Building Regulations.

The intention is to limit solar gains during the summer period to either remove or reduce the need for air conditioning or lower the installed capacity of any air conditioning system, while ensuring that internal conditions are appropriate for the tasks being carried out.

Although AD L2A only requires that solar gains are limited to notional values, AD L2A recognises that for naturally ventilated buildings, limiting solar gain is not always enough to provide a satisfactory level of comfort and advises:

“Therefore the developer should work with the design team to specify what constitutes an acceptable indoor environment in the particular case, and carry out the necessary design assessments to develop solutions that meet the agreed brief”.

Criterion 3 and the BRUKL method are designed to limit solar gains and may not prevent summertime overheating. The method detailed in section 7.6 of this document should be used to assess summertime overheating.

The design should consider energy usage. It should minimise the need for space heating in winter as well as reduce the need for summer cooling.

Paragraph L1 (a) (ii) of Schedule 1 to the Building Regulations requires provision to be made to limit heat losses from pipes, ducts and vessels used in building services.

The Non-Domestic Building Services Compliance Guide¹², provides detailed guidance in support of AD L. It includes guidance on heating and ventilation system performance and on insulating pipework and ductwork.

2.1.3 Part C on Site Preparation, Contaminants, Moisture, Radon

Part C on site preparation and resistance to contaminants and moisture (including Radon) of the Building Regulations applies to all buildings including schools.

¹² Non Domestic building Service Compliance Guide online at www.GOV.UK

Requirement C1 of Schedule 1 to the Building Regulations 2010, states:

“... (2) Reasonable precautions shall be taken to avoid danger to health and safety caused by contaminants on or in the ground covered or to be covered by the building and any land associated with the building.”

Guidance showing ways of complying with requirement C1 is contained in Approved Document C (AD C)¹³. The recommendations in section 2.1.3.1 are a greater provision than the minimum standard in AD C.

For the majority of above ground workplaces including schools, risk assessments should include radon measurements in ground floor rooms where the building is located in a radon Affected Area.¹⁴

2.1.3.1 Radon remediation systems

Radon is an odourless, invisible radioactive gas that is produced continuously in the ground from radioactive decay of naturally occurring uranium and radium, and can be inhaled where it escapes to air. Buildings trap radon presenting an inhalation hazard to occupants. Long term exposure to high radon concentrations increases the risk of lung cancer.

Radon maps identify parts of the country (radon Affected Areas) where high levels, requiring control, are more likely. In relevant areas, radon protection should be installed in new buildings, extensions and refurbishments. Existing buildings in radon Affected Areas and new buildings with radon protection should be tested for radon.

High radon levels in workplaces fall within the scope of the Ionising Radiations Regulations. Established methods, entailing minor building works, should be used where necessary to reduce high radon levels.¹⁵

If a building is constructed with radon protection in the form of an impermeable membrane at foundation level, it is less likely to have high indoor concentrations. This reduces the indoor radon level but it does not completely prevent the entry of radon to the building from the ground.

¹³ 'Approved Document C: Site Preparation and Resistance to Contaminates and Moisture', The Building Regulations 2010, online at: www.GOV.UK

¹⁴ See legal advice on ionising radiation on the [hse website](http://www.hse.gov.uk)

¹⁵ See BRE reports BR211, "Radon: Guidance on protective measures for new buildings" and FB 41 "Radon in the workplace: A guide for building owners and managers: Second edition".

Any new building located in a radon Affected Area should be tested for radon once occupied, regardless of protection measures included when the building was constructed.

If high radon levels are found, established remedial measures should be used. If the building is in an area where radon risk is high, it may already have part-remediation in which case this can be completed and activated through minor building works.

Once remedial work is complete, the indoor radon levels should be measured to confirm the operation of the remedial measures and the records retained. Most remedial measures use low power electrical fans designed for continuous long-term operation.

Although underfloor ventilation systems are typical, there may be air-handling systems within rooms that contradict the normal direction of flow required for the supply of outdoor air and vents that are contrary to the requirements for energy efficiency. These systems should be labelled and checked periodically to ensure their continued operation with an annual radon measurement.

For buildings in high radon areas without remediation systems, repeat radon measurements should be made after any substantial building work.

Further guidance on radon is available from Public Health England (PHE)¹⁶ and guidance for employers is available from the Health and Safety Executive (HSE)¹⁷.

2.1.4 Work on existing buildings

When a building's use changes¹⁸, the Building Regulations apply to the building, or that part of the building, which is subject to the change of use.¹⁹ For example, conversion of an office building or factory into a school building would be a material change of use.

The Building Regulations define windows as a controlled fitting. Therefore, when windows in an existing building are replaced, the work should comply with the requirements of Building Regulations Part K (or Part N in Wales), and Part L.²⁰ After the work, compliance with other applicable parts of Schedule 1 (Parts B, F and J) should be at the same level or better than it was before the work.

¹⁶ Online at the PHE UK radon [webpage](#)

¹⁷ Online at the HSE ionising radiation [webpage](#) and the radiation toolbox [webpage](#)

¹⁸ As defined by the Building Regulations, Regulations 5 and 6.

¹⁹ The Building Regulations 2010 No. 2214, online at www.legislation.GOV.UK

²⁰ See [References section, ref. 1](#) for titles of Approved Documents in support of Building Regulations.

When buildings are refurbished to a significant level it is a requirement of AD L2 to improve thermal performance. As part of this process, ventilation and summertime thermal performance should be considered.

When windows that were providing adventitious ventilation through leakage are replaced then the effect of more airtight new windows may be to increase the risk of condensation. In this case some additional means of ventilation may need to be provided to overcome the increased risk.

Installers of replacement windows in schools who are registered with a relevant competent person scheme are allowed to self-certify compliance with the Building Regulations.²¹ Other installers proposing to replace windows in schools must notify a Building Control Body and will need to prove compliance with Parts F, K and L.

2.2 Health and safety legislation

A number of aspects of Health and Safety legislation apply to schools including:

- The Workplace (Health, Safety and Welfare) Regulations, 2013
- The Control of Substances Hazardous to Health (COSHH) Regulations - see HSG 258
- The Health and Safety (Display Screen Equipment) Regulations, 1992
- The Management of Health and Safety at Work Regulations, 1999

2.3 School Premises and Workplace Regulations

In England, the School Premises Regulations, 2012 and the Independent School Standards, 2012 apply. These do not cover ventilation or temperature in schools but refer to the Workplace Regulations. In Wales, the School Premises Regulations, 1999 apply and include requirements on ventilation and temperature.

The Workplace (Health, Safety and Welfare) Regulations, 2013 apply to schools and cover a wide range of basic health, safety and welfare issues including both ventilation and temperature. The Approved Code of Practice (ACoP), L24, 2013 gives guidance on the application of the Regulations.

²¹ See the competent person scheme current schemes webpage online at www.GOV.UK

Regulation 6 – Ventilation states:

“(1) Effective and suitable provision shall be made to ensure that every enclosed workplace is ventilated by a sufficient quantity of fresh or purified air.

(2) Any plant used for the purpose of complying with paragraph (1) shall include an effective device to give visible or audible warning of any failure of the plant where necessary for reasons of health or safety.”

Regulation 7 on Temperature requires that during working hours, the temperature is reasonable; and that excessive effects of sunlight on temperature are avoided.

The ACoP guidance includes the following points:

- air that is introduced should, as far as possible, be free of any impurity, which is likely to be offensive or cause illness - where necessary, the inlet air should be filtered to remove particulates
- where necessary, mechanical ventilation systems should be provided
- occupants should not be exposed to uncomfortable draughts
- the fresh air supply rate should not normally fall below 5 to 8 litres per second, per occupant
- if the temperature is uncomfortably high because of building design, reasonable steps should be taken to achieve a reasonably comfortable temperature, for example by:
 - insulating hot plant or pipes
 - providing air-cooling plant
 - shading windows
 - siting workstations away from sources of radiant heat
- if a reasonably comfortable temperature cannot be achieved throughout a workroom, local heating or cooling should be provided - in extremely hot weather, fans and increased ventilation may be used instead of local cooling
- in areas of the workplace other than workrooms, such as toilets and rest facilities, temperatures should be reasonable - changing rooms and shower rooms should not be cold
- protection from excessive solar radiation can be achieved by introducing shading and using reflective materials - some examples of the measures which can achieve this, either in isolation or in combination, are:
 - awnings or
 - internal or external blinds
 - dense vegetation, eg trees to provide shading

- upgrading glazing or using films
- overhangs or recesses to windows
- reducing unnecessary glazing on the sides of the building receiving the most sunshine
- improving the thermal mass of the building by using materials which allow heat to be stored and released at cooler times of the day
- air movement is an important control measure and should not be restricted by using the measures above
- when commissioning the design and construction of a new building, consider minimising solar effects by suitable orientation, type of glazing and use of thermal mass

2.4 DfE performance standards for teaching and learning spaces

In addition to the general ventilation requirements of section 6 of AD F, the DfE has set the following performance standards for teaching and learning spaces which ensure compliance with Regulation 6 of the Workplace Regulations on Ventilation as described in section 2.3 above. These standards must be followed if a school building is to comply with BB101.

1. Where mechanical ventilation is used, or when hybrid systems are operating in mechanical mode in general teaching and learning spaces, sufficient outdoor air should be provided to achieve a daily average concentration of carbon dioxide (CO₂) of less than 1000 ppm, during the occupied period²², when the number of room occupants is equal to, or less than the design occupancy.

The maximum concentration should also not exceed 1500 ppm for more than 20 consecutive minutes each day when the number of room occupants is equal to, or less than the design occupancy.

2. In general teaching and learning spaces where natural ventilation is used or when hybrid systems are operating in natural mode the following standards apply:
 - a. sufficient outdoor air should be provided to achieve a daily average concentration of CO₂ of less than 1500 ppm, during the occupied period, when the number of room occupants is equal to, or less than the design occupancy.

²² See Section 8.1 for modelling assumptions including the occupied period

- b. the maximum concentration should also not exceed 2000 ppm for more than 20 consecutive minutes each day, when the number of room occupants is equal to, or less than the design occupancy.
- c. the system should be designed to achieve a carbon dioxide level for the majority of the time of less than:
 - i. 1200 ppm for a new building (800 ppm above the outside carbon dioxide level, taken as 400ppm) for the majority of the occupied time during the year - this is the criterion for a category II building
 - ii. 1750ppm for a refurbished building (1350ppm above outside air level) for the majority of the occupied time during the year - this is the level for a category III building.²³

Except as described in section 2.9 on gas safety, ventilation should be provided to limit the concentration of CO₂ to the levels in paragraphs 1 and 2 above.

CO₂ levels should be measured at seated head height in all teaching and learning spaces.

Annex A: 'Carbon dioxide levels in schools' explains why the design standards in paragraphs 1 and 2 are different for mechanical and natural ventilation.

Ventilation openings should be designed to provide these CO₂ levels based on the maximum number of occupants the space accommodates.

These performance standards are based on the need to control CO₂ released by the respiration of occupants.

In teaching and learning spaces, in the absence of any other major pollutants, carbon dioxide is the key indicator of ventilation performance for the control of indoor air quality.

2.4.1 Ventilation of practical spaces

Higher ventilation rates may be required for practical activities, such as science, design and technology and food technology.

²³ See Table 6.7 for definitions of categories.

In these practical spaces, higher levels of CO₂ are acceptable for the periods of time when Bunsen burners, cookers and other gas-fired appliances are in use as described in section 2.9.

When practical spaces are used as conventional classrooms, the design needs to provide ventilation for teaching and learning activities as described in section 2.4.

These spaces may need additional ventilation during practical activities to prevent the build-up of unwanted pollutants.²⁴

Local Exhaust Ventilation (LEV) is often required to deal with specific processes or pollutant sources that produce moisture, dust or fumes.

LEV should be provided, subject to risk assessments carried out under the Control of Substances Hazardous to Health (COSHH) Regulations 2002.^{25,26} LEV is required in science and design and technology (D&T) practical spaces and preparation rooms and in some art practical spaces.²⁷

2.5 Ventilation of other buildings and non-teaching spaces

Requirement F1(1) of the Building Regulations may be satisfied by following the appropriate design guidance for the types of buildings given in table 6.3 of AD F, 2010, or in BB101.

Further guidance for particular spaces in schools including offices is given in section 5 and in the ESFA: Output Specification, Generic Design Brief, Technical Annex 2F 'Mechanical services and public health engineering'.

2.6 Local extract ventilation

One method of compliance with Requirement F1(1) is the local extract of moisture and other indoor pollutants at the point of generation. Extra ventilation may be needed in spaces such as laboratories, server rooms, D&T spaces, kiln rooms, food technology rooms and kitchens to extract moisture, fumes, dust and heat.

²⁴ See section 5 for more information.

²⁵ See CLEAPSS Model Risk Assessments and CLEAPSS Guide G225 Local Exhaust Ventilation in D&T.

²⁶ Health and Safety Executive, Control of Substances Hazardous to Health (COSHH) Regulations 2002, - www.hse.GOV.UK/coshh.

²⁷ See section 5.8 for guidance on LEV.

Local extract is required from processes or rooms where water vapour or pollutants are released through activities such as showering, cooking or chemical experiments. Extract ventilation may be intermittent or continuous.

Local extract to the outside should be provided in sanitary accommodation, washrooms and food and beverage preparation areas.

Printers and photocopiers used frequently or continuously, may need to be isolated (to avoid any pollutants entering the occupied space) and local extract should be provided.²⁸

2.7 Indoor air quality and ventilation

Achieving good indoor air quality in schools depends on minimising the impact of indoor sources of pollutants, as well as reducing outdoor pollutant ingress by effective design of the building and operation of the ventilation systems.²⁹

AD F gives recommended performance levels for indoor air quality in offices. This guidance also applies to schools. These performance levels are generally in line with the World Health Organization (WHO, 2010) indoor air quality guidelines.

This document quotes the WHO guideline performance levels as they are currently more up to date and comprehensive than those given in AD F. See table 6-1 for an overview and comparison of the various pollutant threshold levels.

2.8 Prevention of overheating in warmer weather

Ventilation rates to achieve adequate indoor air quality may not be high enough to remove significant thermal gains. In warmer weather higher ventilation rates will often be needed to avoid overheating.

Buildings designed in accordance with section 7 will reduce the risk of overheating and ensure compliance with the Workplace Regulation 7 requirement to reduce summertime overheating, see section 2.3.

²⁸ Further guidance on local extract ventilation is given in section 5.2.

²⁹ See section 6 for extra guidance on this.

2.9 Gas safety regulations and standards

The primary gas regulations applying to educational establishments are the Gas Safety (Installation and Use) Regulations (GSIUR).³⁰

The guidance to comply with these regulations is provided in a number of standards produced by the Institution of Gas Engineers and Managers (IGEM) covering the design, construction and maintenance of gas installations and in relevant British Standards and UKLPG documents.

Detailed guidance on the application of the regulations in schools is given in IGEM UP 11 'Gas installations for educational establishments'.³¹

This section and section 5 describe methods of installation to assist in compliance with the regulations (GSIUR) and describe how they affect the design of particular spaces in schools that are associated with gas pipework and gas appliances.

IGEM UP 1101 'Guidance on gas installations for the management and staff within educational establishments' gives advice for school managers and staff which should be included in Building User Guides.

See also IGEM UP 2, edition 3 'Installation pipework on industrial and commercial premises'.

Gas appliances in schools can be of three types.

- a. Type A flueless appliances are those that do not require a flue to be fitted to them and include Bunsen burners, some types of flueless gas fire, and most domestic and catering cookers or ranges
- b. Type B require a flue pipe and are referred to as open flued appliances (such as a gas fire, a kiln or some types of larger specialist cooking appliance, for example, fish fryer ranges)
- c. Type C are referred to as room sealed (or balanced flue) and are typical of modern domestic or commercial gas boilers and may be used for heating.

³⁰ GSIUR online at [gov.uk legislation website](http://gov.uk/legislation)

³¹ IGEM UP 11: Gas Installations for Educational Establishments online at the [IGEM website](http://www.igem.org.uk)

2.9.1 Gas interlocks

An interlock between gas supply and mechanical ventilation is needed to ensure that gas will not be supplied when there is an inadequate airflow. This is for safe operation of appliances and equipment and the safety of personnel.

For Type B appliances: Regulation 27(4) of GSIUR requires that any mechanical extract system that is required for safe operation of the appliances must be interlocked with the gas supply.

IGEM UP 19 provides more detailed requirements for interlock systems. It states that:

“For Type B appliances, environmental monitoring such as CO₂, temperature or humidity may be used in conjunction with variable speed drive (VSD) systems. However, fan flow/pressures switches or power monitoring shall always be used in conjunction with Type B catering appliances. CO₂, temperature or humidity monitoring is not acceptable as the main interlock for Type B catering appliances.”

For Type A appliances: where an appliance is served by a mechanical extract system that is required for safe operation of the appliances, IGEM UP 19 ‘Design and application of interlock devices and associated systems used with gas appliance installations in commercial catering establishments’, 2014, requires that the mechanical extract system must be interlocked with the gas supply. IGEM UP 19 states that:

“For new installations, CO₂ monitoring would normally be used in conjunction with either a fan flow/pressure switch or fan power monitoring (see above and Sub-Section 5.2), but may be used alone with Type A appliances. For Type A appliances, environmental monitoring measuring CO₂ may be used in conjunction with other air quality sensors such as temperature or humidity to provide information to be included in an interlock system. It may also be used as part of a demand control ventilation system.”

Type A appliances may therefore use CO₂ detectors or fan flow/pressures switches or power monitoring interlocks.

Section 4.2 of IGEM UP 19 describes CO₂ and other interlock systems for catering establishments and should be referred to when designing CO₂ interlocks for food

technology spaces in schools. See also section 5.6 of this document on food technology spaces.

In science and design and technology practical spaces with only Type A appliances, it is relatively simple to use a CO2 monitoring and interlock system. See section 2.9.2.

For Type A appliances, a common extract duct from extraction canopies can be used with a wall mounted CO2 interlock system as IGEM UP 19 requires the ventilation system to be interlocked and must be in operation before gas is available to cookers.

For Type B appliances, a wall mounted CO2 interlock can be used with a common extract duct from extraction canopies but **only as a secondary interlock** and not as the primary main interlock which should be as described in IGEM UP 19.

Table 2-1 summarises the choices of different types of gas safety interlocks for schools.

Table 2-1 Summary of interlock requirements according to appliance type.

Interlock system type	Appliance Type A	Appliance Type B	Appliance Type C	Comments
Flow switch or air pressure switch	Yes	Yes as a primary interlock	Not needed	Simple system. Does not prove environmental conditions.
Mechanical ventilation fan power monitoring	Yes	Yes as a primary interlock	Not needed	Simple system, may be slightly better than above. Does not prove environmental conditions.
CO2 monitoring	Yes	Yes as a secondary interlock but only with a primary interlock	Not needed	For legal reasons not permitted alone with Type B. Provides positive proof/control of the environment for Type A. Suitable system for teaching spaces in which there are only Type A appliances. Easy to apply in schools having environmental control system.
Variable Speed Drive with CO2 monitoring and control	Yes	Yes as a secondary interlock but only with a primary interlock	Not needed	Reduces power consumption and fan noise through demand controlled ventilation. Most suitable system for teaching spaces in which there are only Type A appliances.

Central school catering must comply with IGEM UP 19 and BS 6173.

Boiler plant rooms including gas, Combined Heat and Power (CHP) and gas fired plant must comply with IGEM UP 3, IGEM UP 10, BS 6644 and other associated standards for different plant types.

2.9.2 Gas safety interlocking by environmental/CO₂ monitoring

Where only Type A appliances are used, interlocking may be achieved by environmental monitoring of carbon dioxide as described in IGEM UP 19.

Environmental CO₂ monitoring can be used in most food technology rooms, ie spaces that only contain Type A appliances and in science as Bunsen burners are classed as Type A appliances.

In accordance with IGEM standards, gas interlocks by environmental monitoring of CO₂ should operate as follows:

- a. During practical activities, the appliances shall not cause the CO₂ level to exceed 2800ppm, which will produce a signal warning of a high CO₂ level
- b. An automatic gas shut down shall operate when the level of 5000ppm of CO₂ is reached

At 2800 ppm supply and extract systems should be automatically switched on or boosted and the teacher should be warned that ventilation needs to be increased. Systems to control the ventilation to keep it under 2800ppm can include individual canopies vented externally, supply air fans or opening windows. Below 2800 ppm these ventilation systems can be under automatic demand control with teacher or user override control so that noise levels can be easily controlled and energy use can be minimised. Openable windows alone is not an adequate means to control CO₂ levels in these practical spaces.

When practical activities are not taking place and gas is not in use the ventilation in practical spaces should be controlled to meet the normal CO₂ levels for teaching and learning spaces as described in section 2.4.

2.9.3 Carbon monoxide, carbon dioxide and flammable gas detectors

For schools applications, any carbon monoxide (CO) or CO₂ detection systems need to comply with a standard suitable for their use and must be regularly maintained.

2.9.3.1 Carbon monoxide detectors

Chimneys and flues should be designed and installed so that they are in a position that allows for suitable inspection and checking in the future. Inaccessible chimneys or flues should be avoided.

IGEM UP 11 recommends that CO detection systems are located in any occupied spaces through which, or next to which, chimneys or flues pass. This protects against leakage from within chimneys which may not always be totally accessible for visual and other inspections. However, for new installations, this practice should be avoided unless suitable and detailed plans for ongoing inspection and maintenance of the chimney or flue have been developed.

IGEM UP 11 recommends that CO detectors are located adjacent to kilns, positioned in accordance with the manufacturer's instructions, as even during normal use they can produce significant levels of CO as part of the process of obtaining colours in the glazes.

It is not considered that there is a need for CO detection in boiler houses that have been correctly designed and ventilated in accordance with current industry practice such as the guidance contained in IGEM UP 10. However CO detection equipment should be fitted where called for by a site specific risk assessment.

CO alarms compliant with BS EN 50291 are specifically designed and tested for domestic and recreational spaces. This standard is not intended for detectors for use in schools or workplaces.

Detectors complying with BS EN 45544 Part 3³² may be used, but compliance with this standard is not compulsory and some of the requirements of this standard are intended for much more arduous industrial environments than schools.

The variety of applications for CO detection within educational establishments requires the selection of the most appropriate CO detector for each location. For example, it could be that a detector declaring compliance with only some aspects of BS EN 45544 Part 3 would be appropriate within a boiler room adjacent to a corridor. Whereas more of the requirements or clauses might be relevant for a more process combustion orientated location.

³² BS EN 45544 Part 3, Workplace atmospheres - Electrical apparatus used for the direct detection and direct concentration measurement of toxic gases and vapours - Part 3: Performance requirements for apparatus used for general gas detection.

CO detection systems should be compliant with relevant standards. They must be installed and located in accordance with manufacturer's instructions. CO detectors in new installations should be hard wired.

2.9.3.2 Carbon dioxide detectors

CO₂ detectors used for gas safety interlock systems in science labs, food technology rooms and catering kitchens shall comply with the relevant parts of BS EN 50543, as listed in IGEM UP/11. They are required to give an audible alarm and be linked with an automatic gas shut off system, which will be fail-safe and require manual intervention in order to restore the gas supply.

Detectors must be installed in accordance with manufacturer's instructions and should be hard wired.

Where CO₂ monitors are employed as part of the ventilation control or alarm strategy; the monitors shall be placed in an area that reflects the general CO₂ levels within the practical area or cooking area. Typically they should be fitted horizontally between 1 m and 3 m from the cooking or practical areas and approximately 2.5 m above floor level. They should not be located in high velocity air streams such as close to the edge of a canopy or adjacent to an air supply or extract position.

2.9.3.3 Flammable gas detectors

IGEM UP 2 gives guidance on boiler rooms that may require flammable gas detection. Flammable gas detection should be provided in any boiler room that is LPG fired. Particular attention needs to be given to the selection and location of flammable gas detection systems where LPG is supplied to boiler rooms. Information on risk assessments is given in IGEM UP 16.³³

³³ IGEM UP 16 'Design for Natural Gas installations on industrial and commercial premises with respect to hazardous area classification and preparation of risk assessments'.

3 Summary of regulations and guidance

Table 3-1 is a quick reference guide that shows which parts of BB101 are regulatory, which are ESFA recommended design standards, and which are for further information and guidance. The regulatory standards are described in full in section 2. The recommended standards for ESFA projects can also be found in the ESFA Output Specification: Generic Design Brief and Technical Annexes, in particular Technical Annex 2F: ‘Mechanical services and public health engineering’, published in 2017.

Table 3-1 Summary of Regulations and guidance

	Regulations and statutory guidance	ESFA recommended design standards – Non statutory guidance	Further information and guidance – beyond the ESFA recommended design standards
Indoor air quality Ventilation rates Location of controls	Sufficient outdoor air should be supplied to general classrooms to maintain the average occupied CO2 levels, eg 1000ppm/1500ppm. See section 2.4. IGEM UP/11 allows higher level of CO2 of up to 2800ppm, with safety interlock to shut off at 5000ppm, during practical work using gas fired equipment. See section 2.9.	Ventilation for particular areas and activities. See section 5. Monitoring and logging building performance using zone CO2 sensor/logger. See section 4.8 ‘Control of ventilation’ and ESFA Output Specification, and Generic Design Brief, Technical Annex 2I: ‘Controls’ (ESFA GDB Annex 2I: Controls).	Demand controlled ventilation using temperature and carbon dioxide sensors.

	Regulations and statutory guidance	ESFA recommended design standards – Non statutory guidance	Further information and guidance – beyond the ESFA recommended design standards
<p>Indoor air quality</p> <p>Pollutant levels</p>	<p>AD F Appendix A gives maximum recommended pollutant levels.</p> <p>HSE EH40 gives maximum workplace exposure levels.</p> <p>AD F gives guidance on the typical urban pollutants that need to be considered, the location and control of ventilation intakes, and the location of exhausts.</p>	<p>The correct level of filtration should be provided to Air Handling Units in line with Regulations including AD F and local planning requirements.</p> <p>Section 4.3.15, ESFA GDB Annex 2F: Mechanical Services and public health engineering.</p> <p>Internal finishes and fittings provided should be such that levels of Volatile Organic Compounds in the air do not exceed 300µg/m³ averaged over eight hours. ESFA GDB, Annex 2D: Internal elements and finishes.</p>	<p>CIBSE Guide A, table 1.5 lists filtration grade G3 or M5 for protection of mechanical ventilation with heat recovery equipment.</p> <p>Best practice is to follow the latest WHO indoor air quality guidelines. The World Health Organisation (WHO, 2010) indoor air quality guidelines give more up to date maximum pollutant levels than the current AD F and cover more pollutants. See table 6.1 and section 6.</p> <p>National Air Quality Standards: Consideration of measures to reduce pollutant levels where they exceed the NAQS.</p> <p>How to meet planning requirements for air quality in Air Quality Management Areas.</p> <p>Reducing indoor air pollutant sources.</p> <p>Specification of low pollutant emitting Furniture and Equipment. See section 6.4.</p>

	Regulations and statutory guidance	ESFA recommended design standards – Non statutory guidance	Further information and guidance – beyond the ESFA recommended design standards
			<p>Guidance on BS EN 13779, BS EN 779 and BS EN 16890 for higher filter specifications that may be required in polluted areas. See section 6.5.</p> <p>Consider the suitability of external air as a supply of outdoor air. Positioning and controlled opening of windows and vents or use of filters may be required.</p> <p>See section 6.5 including section 6.5.2 for filter specifications.</p>
<p>Indoor air quality</p> <p>Pollutant levels</p>	<p>Radon concentration threshold is specified in the Ionising Radiations Regulations; above which the regulations apply.</p>	<p>Building Research Establishment (BRE) report BR211: guidance on areas where radon protection may be needed.</p>	<p>BRE 211 gives guidance on testing buildings with protective measures for radon. Guidance on testing other new buildings and remediating high radon levels is available from PHE online at the ukradon webpage</p>

	Regulations and statutory guidance	ESFA recommended design standards – Non statutory guidance	Further information and guidance – beyond the ESFA recommended design standards
Thermal comfort	Workplace Regulations	<p>Thermal comfort for more vulnerable pupils will generally need higher category comfort criteria and particular needs of pupils should be considered.</p> <p>Overhead radiant heating panel sizing tool to limit radiant temperature asymmetry. See section 7.4.</p> <p>Maximum floor surface temperatures for underfloor heating that should not be exceeded during normal occupation. See section 7.5.</p> <p>Central control of heating set points and run times with local control of heat emitters. See section 4.8 and ESFA GDB, Annex 2I: Controls.</p> <p>Monitoring and logging performance using temperature sensor/logger. See ESFA GDB Annex 2I: Controls.</p>	<p>ISO 7730 is underlying comfort standard.</p> <p>Risk assessments are needed for surface temperatures and low surface temperature (LST) emitters may be required for more vulnerable pupils.</p>

	Regulations and statutory guidance	ESFA recommended design standards – Non statutory guidance	Further information and guidance – beyond the ESFA recommended design standards
Thermal comfort Summertime Overheating		BS EN 15251 and CIBSE TM 52 adaptive thermal comfort criteria that apply to free running buildings, see section 7.6 and 7.7 CIBSE Guide A comfort criteria for air conditioned buildings apply to mechanically cooled parts of buildings, ie non free running parts of buildings.	Outlets within 200mm of slab to prevent build-up of hot air at ceiling level. Use of passive thermal mass in preference to active cooling systems. See section 4.13.1.
Thermal comfort Prevention of cold draughts		Ensure delivery of outdoor air does not cause cold draughts. See section 7.3. Natural Ventilation systems: Use window and damper draught calculator to assess draughts. See section 7.3.1. Mechanical ventilation systems and hybrid systems in mechanical mode: Maximum local air speed and temperature of supply air when it reaches the occupied zone to be in	

	Regulations and statutory guidance	ESFA recommended design standards – Non statutory guidance	Further information and guidance – beyond the ESFA recommended design standards
		accordance with section 7.3.2 and tables 7.3 and 7.4.	
Window design Glass safety Window restrictors	AD K - Protection from falling, collision and impact	Sill heights for different age groups and window restrictors for safety. See ESFA GDB Annex 2C: External Fabric. Actuators for window opening need to be robust and serviceable. Openable areas using effective area as defined in section 8.3 and annex D	
Ventilation design Local extract rates	AD F	Extract rates in section 5.2 and table 5.1. Cooling may be required for reprographics rooms in addition to extract ventilation required to remove pollutants from photocopying machines.	

	Regulations and statutory guidance	ESFA recommended design standards – Non statutory guidance	Further information and guidance – beyond the ESFA recommended design standards
		<p>For gas safety, cooker extract rates are higher than those given in AD F and are based on IGEM UP 11.</p> <p>Extract for central groups of toilets should be continuous not intermittent.</p>	
Ventilation design	<p>Workplace Regulations on Ventilation</p> <p>Ventilation heat loss is subject to Part L energy performance limits.</p>	<p>Classroom based ventilation systems may require higher flow rates to allow for limited recirculation due to proximity of intake and extract grilles. See section 4.4, and table 4.1.</p> <p>Take account of prevailing winds, flue positions, kitchen extracts, fume cupboard flues and vehicle fumes.</p> <p>Minimise unintentional recirculation.</p> <p>DW/172 for kitchen ventilation systems and exhausts. See section 4.4.3 and section 5.9 on Catering kitchens.</p>	<p>Use ASHRAE 62-1, ASHRAE Applications Handbook, Chapter 45 and/or EN13779 air classes, building geometry and separation distances for supply and extract where possible. See section 4.4.</p> <p>Position of exhausts, extracts, external louvres, air intakes and incoming air vents; to prevent ingress of external pollution sources. See section 4.4.</p>

	Regulations and statutory guidance	ESFA recommended design standards – Non statutory guidance	Further information and guidance – beyond the ESFA recommended design standards
Fume extract	COSSH Regulations	<p>HSG 258</p> <p>Fume cupboard exhaust to terminate 3m above roof level, or outside rooftop recirculation zones; to BS EN 14175 Part 3 recommended discharge height and efflux velocity or calculations to CIBSE/ASHRAE guidance. See ASHRAE Applications Handbook, Chapter 45: Building air intake and exhaust design and ASHRAE 62-1.</p> <p>Fixed ducted fume cupboards required in prep rooms.</p>	Ducted semi-mobile fume cupboards preferable to mobile recirculatory fume cupboards in schools. See CLEAPSS Publication G9a, 'Fume Cupboards in Schools'.
Gas safety	<p>Gas Safety (Installation and Use) Regulations</p> <p>CO detectors in rooms through which a gas flue passes even if boxed in. IGEM UP 11 and section 2.9.1.</p>	<p>Section 2.9 'Gas safety regulations and standards'.</p> <p>IGEM Standards including:</p>	<p>Food technology rooms are not considered as 'commercial catering'.</p> <p>Environmental/CO2 monitoring suggested method of gas safety interlock in food technology rooms and science labs where there are only Type A appliances.</p>

	Regulations and statutory guidance	ESFA recommended design standards – Non statutory guidance	Further information and guidance – beyond the ESFA recommended design standards
	Gas safety interlocks on ventilation. See section 2.9.	<p>IGEM UP 11 'Gas installations for educational establishments'.³⁴</p> <p>IGEM UP 1101 'Guidance on gas installations for the management and staff within educational establishments'.</p> <p>IGEM UP 2, edition 3 'Installation pipework on industrial and commercial premises'.</p>	<p>See section 2.9, IGEM UP 11 and IGEM UP 19.</p> <p>IGEM UP 1101 'Guidance on gas installations for the management and staff within educational establishments'.</p>

³⁴ Institute of Gas Engineers and Managers, UP 11: Gas Installations for Educational Establishments - www.igem.org.uk/Publications_Information.html.

4 Design

4.1 Ventilation strategy

The choice of ventilation strategy needs to take account of:

- the comfort criteria to be achieved³⁵
- building layout
- choice of building fabric
- orientation
- glazing
- occupancy
- usage patterns
- external noise levels and noise transmission³⁶
- sources of air pollution
- heating and cooling provisions
- room pollutants
- expected solar gain

In certain circumstances 100% natural ventilation can be used, eg in high spaces such as halls. In some polluted environments 100% mechanical ventilation including filtration may be required.

During refurbishment work, opportunities should be taken to:

- prevent summertime overheating
- replace excessive glazing
- provide shading
- reduce solar gain and glare
- increase ventilation rates

4.2 Natural ventilation

Natural ventilation occurs either due to the buoyancy or stack effect or due to wind pressure.

Single-sided ventilation that relies solely on openings on one side of the room has a limiting depth for effective ventilation of typically 5.5m or 2 times the room height.

³⁵ See section 7.

³⁶ See BB93, 2015 and IoA and ANC Acoustic design of schools: a design guide, 2015.

Separating the openings sufficiently vertically can increase the effective depth to 2.5 times the room height.

Cross-ventilation occurs when there are ventilation openings on both sides of a space. Across the space there is a reduction in air quality as the air picks up local pollutants and heat, limiting the effective depth for ventilation to typically 15m or 5 times the room height.

For cross ventilation, openable areas are needed on opposite sides of the space. This can be achieved by the use of stacks or clerestory windows. However stacks take up valuable floor space on the floor above. See CIBSE AM10 for design guidance on wind and stack ventilation.

Calculation methods for natural ventilation to determine the effective opening areas are described in section 8.3.

4.2.1 Design of natural ventilation openings

For a natural ventilation system to control overheating in summertime, large volumes of air need to flow through the teaching spaces. This can be achieved through the use of atria (ie central circulation spaces used for ventilation and daylight), cross-ventilation and stacks. This provides a means of removing the internal heat gains while providing ventilation to the occupants.

4.2.2 Design of stack ventilation

Cross flow, stack ventilation via an atrium, circulation space or stack is very useful for preventing overheating, however noise transfer between classrooms and the atrium and other classrooms must be overcome. The buoyancy effect that arises when there is a temperature difference between the inside and outside is greater as the height of the atrium increases; this provides the potential to ventilate the building even when there is no wind.

However, incorrect atria design can lead to airflows that increase overheating rather than reduce it and can also compromise ventilation flows in a fire. Mistakes are often made at design stage and then carried through to construction.

An effective design largely comes down to the correct relative sizing of air vents. When the opening of the atrium at high level is too small compared with the storey vents, reversed flows through the top storey or storeys are common. Conversely, exchange flows at the high-level atrium opening may occur when the atrium vent is too large; or when flows through the storeys are restricted.

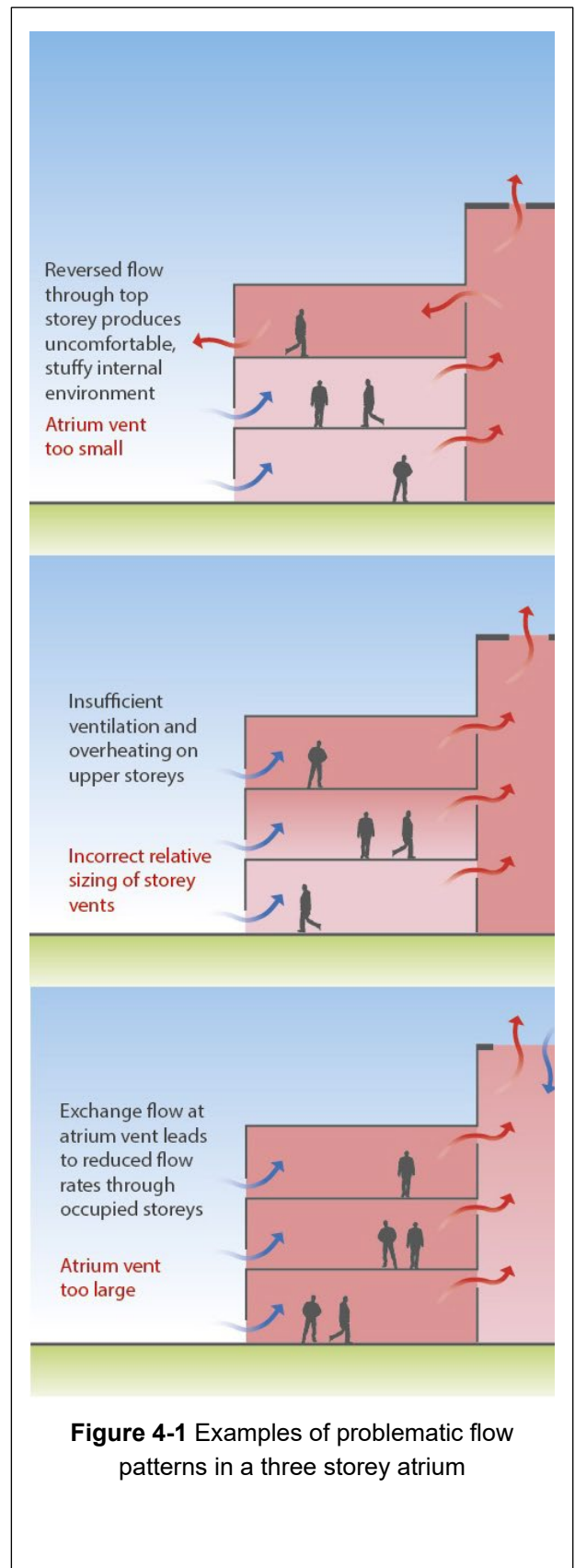

Figure 4-1 Examples of problematic flow patterns in a three storey atrium

Simple models of atria flow have been developed³⁷ to help prevent conceptual design errors which have resulted in the following guidelines:

1. The optimum design has equal per-person vent sizes at high level in the atrium and in the top storey. This shares control between all vents in the zone of the building and ensures a forward flow on all storeys minimising the likelihood of reverse flow on the top storey.
2. Vent sizes should increase in higher storeys, to compensate for the reduction in driving stack pressure from the atrium, thereby avoiding lower flow rates or reverse flow and hence overheating on the upper storeys.
3. The atrium or ventilation stack should extend at least one storey height above the top storey to ensure an enhanced flow through all storeys. If this is not possible because of planning or budgetary constraints, the top storey should be disconnected from the atrium and a different ventilation system employed, for example, cross ventilation provided within the classroom area itself.
4. The atrium enhancement of cross flow ventilation should be greater than 1 on all storeys. For the top storey for example:

$$\text{Atrium enhancement} = \frac{\text{Top-storey ventilation rate with atrium}}{\text{Top-storey ventilation rate without atrium}}$$

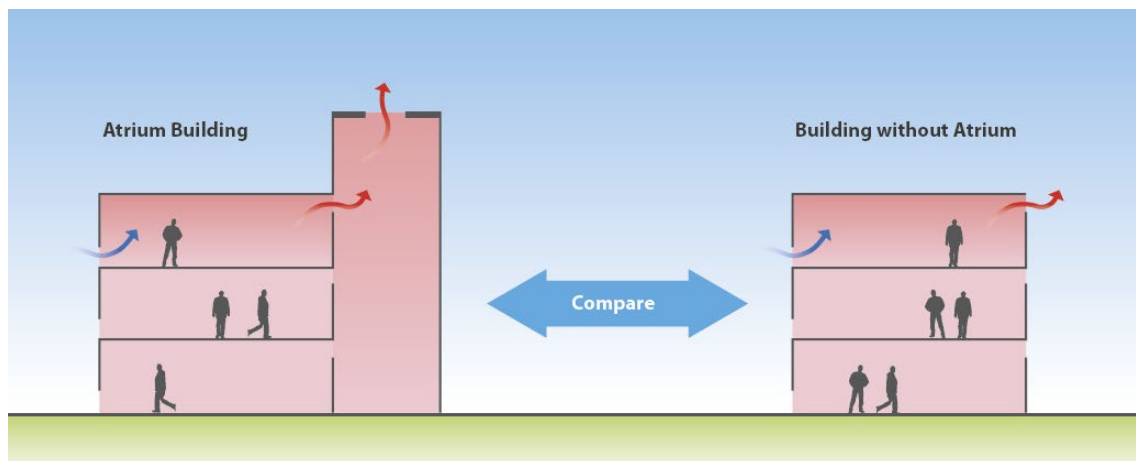

Figure 4-2 Definition of the atrium enhancement metric

³⁷ A Acred 'Back to Basics', CIBSE Journal September 2015;

A Acred & GR Hunt (2013) 'Multiple flow regimes in stack ventilation of multi-storey atrium buildings', International Journal of Ventilation 12-1, 11-40;

A Acred & GR Hunt (2014) 'Stack ventilation in multi-storey atrium buildings: a dimensionless design approach'. Building and Environment 72, 44-52.

See also CIBSE AM10 online at [CIBSE](http://www.cibse.org) website.

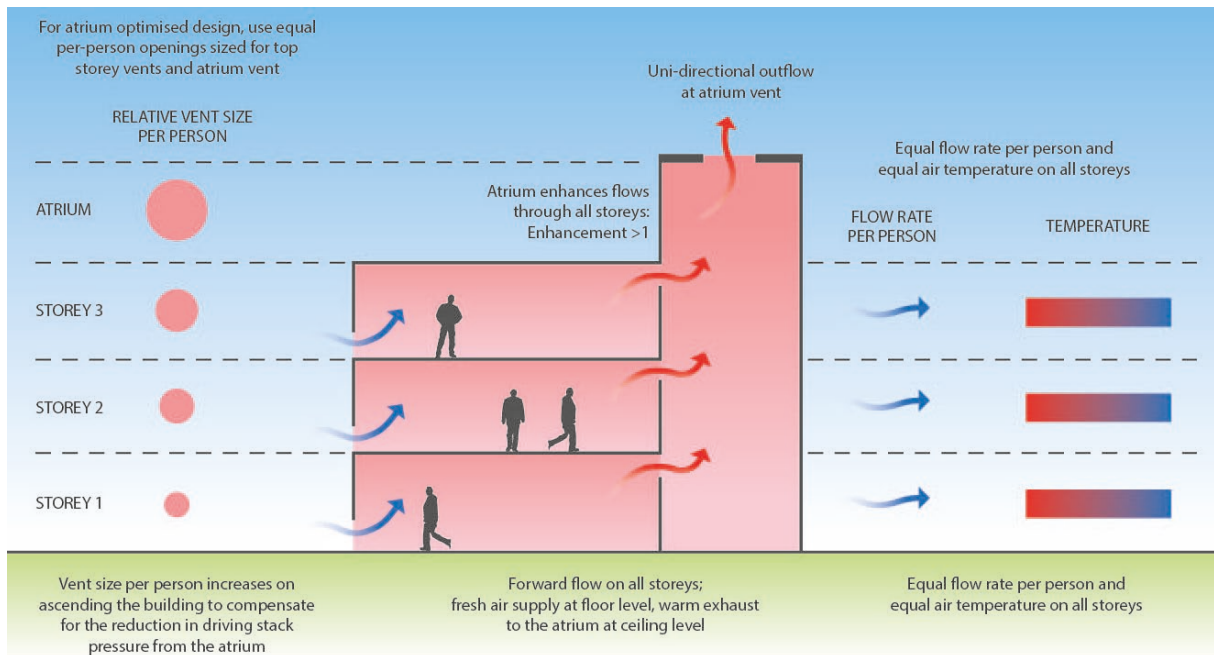

Figure 4-3 Ideal design blueprint for an atrium building.

4.3 Mechanical and hybrid ventilation

Mechanical ventilation takes place when a fan drives the airflow into or out of the building. This can be a centralised system with distribution ductwork, or individual room-based units. Mechanical ventilation with heat recovery (MVHR) can deliver outdoor air that is only heated during start-up.

Heat recovery unit heat exchangers are made of plastic, aluminium or stainless steel. Paper heat exchangers are available but are not recommended.

There should be bypass of the heat recovery elements for use in summertime to prevent overheating.

Heat exchanger efficiencies of up to 84% on a dry-bulb basis are possible (or 92% allowing normal room humidity).

Mixing ventilation systems provide heat reuse within the space and can have similar seasonal energy efficiencies, in room based ventilation systems, to heat recovery units with heat exchangers. This is because:

- new buildings in England have high levels of thermal insulation
- the balance point where no heating is required is around 5°C
- the number of occupied hours when the external temperature is below 5°C is small

In older buildings, that are being refurbished, the balance point can be as high as 15°C. In this case heat exchangers can be more energy efficient as there are a large number of occupied hours when the external temperature is below 15°C.

MVHR supplies filtered fresh air. Most models are able to provide good temperature control, so that the incoming air is already tempered at the point of entry to the room.

Selection of electronic commutation (EC) fan drive motors can result in much improved specific fan powers (SFP). Together with demand control of CO₂, this reduces power demand.

4.4 Location of ventilation air intakes and exhausts

4.4.1 Location of ventilation air intakes

It is important to ensure that intake air is as uncontaminated as possible regardless of the type of ventilation system. This is important in Air Quality Management Areas and Low Emission Zones ³⁸ where pollution levels of at least one pollutant have exceeded the Air Quality Standards ³⁹. The siting of exhausts and fume cupboard discharge stacks is also important. See section 5.7.7.

Guidance on ventilation intake placement for minimising ingress of pollutants is summarised in table 4.1. The guidance is simplified and cannot be applied to all sites. The risks associated with specific sites may need to be assessed by an expert and may require modelling.

³⁸ For Air Quality Management Areas see: [the DEFRA UK Air website](#).

³⁹ Air Quality Management (2002). Air Quality Strategy Wallchart – Summary of Proposed Objectives in the Latest Consultation, November 2002. Gee Publishing.

Table 4-1 Ventilation intake placement to minimise pollutant ingress

(based on Table D1 of Approved Document F)

Pollutant source	Recommendation
<p>Local static sources:</p> <ul style="list-style-type: none"> • parking areas • drop-off zones • loading bays • adjacent building exhausts • stack discharges 	<p>Ventilation intakes need to be placed away from the direct impact of short-range pollutant sources, especially if the sources are within a few metres of the building. Consider the positioning of school parking and drop offs in relation to air intakes.</p>
<p>Urban traffic</p>	<p>Air intakes for buildings positioned directly adjacent to busy urban roads should be as high (at least 2m) and/or as far away as possible from the direct influence of the source so as to minimise the ingress of traffic pollutants. There will be exceptions to this simple guide and these risks may need to be assessed by modelling. In such cases, it is recommended that expert advice is sought.</p> <p>For buildings located one or two streets away, the placement of intakes is less critical.</p> <p>Pollution from railways should be considered.</p> <p>BS EN 13779 recommends standards for the design of ventilation systems to reduce the ingress of outside air pollutants. It includes a classification of outdoor air quality and supply air classes and guidance on filtration classes. See section 6.5.2.</p> <p>Where relevant an air quality assessment may need to accompany a planning application either using monitored data or by a survey or using pollution models such as the UK Air website.</p>
<p>Building features and layout:</p> <ul style="list-style-type: none"> • courtyards • street canyons 	<p>Avoid locating air intakes in courtyards or street canyons where there are air-pollutant discharges.</p> <p>If this is not possible, position them away from the pollutant sources in an open or well-ventilated area.</p> <p>Take steps to reduce the pollutant sources, eg avoid parking and loading during occupied hours as pollutants can accumulate in enclosed areas such as courtyards.</p>

Pollutant source	Recommendation
Multiple sources	<p>Where there are a large number of local sources around the building, consider their combined effect. The façade with the lowest concentration of pollutants is a good place to locate ventilation intakes.</p> <p>Location of intakes may need expert advice, eg for numerical and wind-tunnel modelling.</p> <p>In general, place air intakes as far as possible from pollutant sources, where air is free to move around the intake.</p>
Weather factors	<p>In areas where wind comes from one main direction (eg in a valley location), the air intakes and outlets should point in opposite directions.</p> <p>In complex urban layouts, complex wind flows are likely to occur. In these cases, expert advice may be required.</p>

Further guidance on air intakes and exhausts is given in CIBSE TM21⁴⁰ and ASHRAE Applications Handbook, Chapter 45: Building air intake and exhaust design and ASHRAE 62-1.

4.4.2 Location of exhaust outlets

The location of exhausts is as important as the location of air intakes. Exhaust locations should:

- minimise re-entry to the building through natural and mechanical intakes
- avoid adverse effects to the surrounding area
- be located downstream of intakes where there is a prevailing wind direction
- discharge away from air conditioning condensers

For an individual room, hybrid or MVHR ventilation system, the intake and exhaust can be very close together. Here the design of the external louvres or damper blades can help reduce recirculation. Smoke tests and prototype installations can be used to

⁴⁰ Chartered Institute of Building Services Engineers (1999). CIBSE Technical Memorandum TM21 on Minimising Pollution at Air Intakes, CIBSE Bookshop: ISBN 0 900953 91 8.

refine the design of these units and may be used to demonstrate effective separation of intake and exhaust air. In some cases, to allow for some recirculation, it will be necessary to increase the supply airflow rate.

4.4.3 Exhaust of contaminated or polluted air and combustion products

The siting of chimneys and flues, and exhausts from kitchens, toilets and fume cupboards is important. These exhausts must be separated from air intakes.

CIBSE Guide B 2-96 quotes the following guidance from the ASHRAE, Handbook, Fundamentals, 2013:

Measures that should be considered to minimise re-entry from contaminated sources include:

- careful location of mechanical exhausts to avoid unintentional recirculation - for example, discharge into courtyards, enclosures or architectural screens may cause problems as pollutants do not disperse very readily in such spaces - enclosures or architectural screens may hold contaminants within areas of flow recirculation
- placing inlets on the roof where wind pressures will not vary greatly with direction to ensure greater stability
- discharging exhausts vertically at high level to clear surrounding buildings, and so that downwash does not occur
- locating wall exhausts on the upper third of a façade and intakes on the lower third to take advantage of normal wind separation on a building façade (although consideration should be given to flow recirculation that can occur on a leeward façade)
- avoiding locating inlets and exhausts near edges of walls or roofs due to pressure fluctuations - a central location on the roof is preferable for fume dispersal

Where possible, pollutants from mechanical extracts can be grouped together and discharged vertically upwards. The increased volume will reduce the mixing of the plume and increase the plume height. This is common practice where there are a number of fume cupboard discharges. Adding the general ventilation mechanical exhaust will produce greater plume-height and dispersion.

In accordance with DW 172, kitchen extract discharge points should be positioned such that the extracted air cannot be entrained into a supply system. The ductwork

should discharge at least 1.0 m above any openable window or any ventilation inlet or opening.⁴¹

Flues should be high enough above any roof to ensure that the discharge of fumes is clear of the roof recirculation zones and cannot re-enter the building or any adjoining building.

BS EN 13779 provides a graphical method to calculate the distance between intakes and exhausts. The method considers the separation in height between intake and exhaust, the type of roof, and the type of exhaust air. It classifies exhaust air into EHA1, EHA2, EHA3 or EHA4. It can be used to calculate stack heights and efflux velocities, and separation distances for air intakes and exhausts on central air handling units and kitchen ventilation systems.

For fume cupboard exhausts and other similar exhaust systems dealing with chemical pollutants, eg from laser cutters, see section 5.

Where stack heights are limited, eg by planning constraints, it may be necessary to increase the plume height by increasing the efflux velocity and possibly by using a special flue terminal to entrain air into the plume to increase the plume height.

See section 5.7.7 for guidance on fume cupboard exhausts and building exhaust design.

4.5 Air quality

Where outside air pollutants exceed the levels in The Air Quality Standards Regulations 2010, given in table 6-1, it will be necessary to consider ways to reduce pollutant levels in the indoor air. This is important in Air Quality Management Areas and Low Emission Zones⁴² where outside pollution levels of at least one pollutant have exceeded the Air Quality Standards⁴³.

Designers can find out about current air pollution levels in the area of a school using the 5-day air pollution forecasts provided by the Met Office. These can be found on Defra's UK Air website ([uk-air.defra.GOV.UK](http://uk-air.defra.gov.uk)). The website has a postcode search

⁴¹ DW/172: Specification for Kitchen Ventilation Systems, online at [BSRIA bookshop](http://BSRIA-bookshop.com) website.

⁴² For Air Quality Management Areas look online at [the DEFRA UK-Air website](http://uk-air.defra.gov.uk).

⁴³ Air Quality Management (2002). Air Quality Strategy Wallchart – Summary of Proposed Objectives in the Latest Consultation, November 2002. Gee Publishing.

facility providing localised information about latest measured levels of air pollution and relevant health advice.

4.6 Filtration and air purification

Filtration may be needed for two reasons:

- to prevent dirt accumulating in air handling plant including on heat exchangers and ductwork
- to filter out external pollutants

Filtering out pollutants that have health effects requires more expensive filters than the simpler, cheaper and less efficient filters required to protect air handling plant. See section 6.5.2 for further guidance on filtration.

4.7 The Coanda effect

The Coanda effect can be used in colder weather if the temperature of the air supply jet is near to room temperature and the velocity is high as provided by a fan driven system. The Coanda effect occurs when a high velocity jet close to the ceiling has a lower pressure than the surrounding slow moving warmer room air which is entrained into the jet. The jet is kept up by the higher air pressure of the warm air below. This counteracts the tendency for colder supply air to drop due to its greater density than warm room air. The effect causes the jet to travel across the ceiling and mix with the room air and prevents cold draughts in the occupied zone.

Grille, diffuser and air handling unit manufacturers provide advice on their products which use this effect to throw air a considerable distance in a space before it drops. However if there are obstructions in the air path such as downstand beams this will prevent the systems from operating as intended and cold draughts may result. If the air speed of the supply air jet reduces, eg due to demand control, there comes a point at which the plume will detach from the ceiling and it will not reattach again until the air velocity is increased significantly. Variable speed fan controls in systems that use the Coanda effect must allow for this effect.

With single sided natural ventilation systems the Coanda effect is not generally useful in colder conditions, as the driving force of the wind is variable and air speeds are insufficient to prevent the cold, denser incoming air dropping onto occupants and causing discomfort. With cross and stack ventilation, the Coanda effect may be able to be utilised due to the smaller openings required and hence higher air speeds.

4.8 Control of ventilation

It is important that ventilation controls allow the user to

- reduce ventilation rates when required, for example with low occupancy
- allow for out of hours use
- increase ventilation in summertime
- maintain acceptable indoor air quality
- avoid cold draughts
- avoid excessive energy consumption in the heating season

Where possible carbon dioxide sensors should provide monitoring and demand control of ventilation systems.

Environmental control by means of a single space temperature and CO₂ sensor, with fan speed and setpoint adjustments for each classroom, will provide effective control of separate ventilation and heating systems. This will prevent control system conflicts which can arise where there is separate control of heating and ventilation systems. Where thermostatic radiator valves (TRVs) provide local room control and there is separate automatic temperature control of the room ventilation system the TRVs should be:

- of the lockable type
- set so that the normal maintained room temperature cannot be exceeded due to operation of the TRVs

It should be possible to maintain adequate ventilation during room dim-out or blackout without impairing security or safety requirements. However, reduced ventilation is acceptable for short periods.

It may be necessary to provide a timed override to allow teachers to shut off room-based ventilation systems during:

- class activities that require low air speeds, eg some science experiments
- activities that need very quiet conditions
- in the event of extreme wind conditions or noisy outside activities

Teachers must have control of the ventilation and understand how to use it.

The building logbook and handover information should include straightforward guidance for the facilities management team. They should also receive explicit training on the operation of ventilation systems, particularly if the systems are complex or controlled by a Building Management System (BMS).

Other school staff need basic training at building handover. Teachers and new starters need simple Building User Guides.

Training and feedback on training should be part of handover and “Soft Landings”.

The set points for control of ventilation are as important as the maximum design target for CO₂. In the case of natural and hybrid ventilation systems the control set points for the ventilation system in teaching spaces, which can include opening windows, should be set to achieve less than 1000ppm whenever possible.⁴⁴

Space temperature control set points should be reduced to take full advantage of night cooling during hot weather and to prevent the heating system coming on unnecessarily before occupancy during the heating season, see section 4.13.2.

4.9 Thermal comfort

Section 7 describes the thermal comfort criteria for the different spaces and activities in a school. It uses the same comfort category descriptions as BS EN 15251, see Table 7-1. It is important to note that a space may have different comfort categories for different thermal comfort criteria. For example a sports hall has a category IV for cold draughts (see table 7-3) but a category III for the summertime overheating risk assessment (see table 7-7).

4.9.1 Control of cold draughts

Wherever possible external doors that are frequently used should have draught lobbies or unheated transition spaces arranged to avoid draughts and heat losses. This is particularly important where there is underfloor heating which has a slow thermal response. Where there are external doors in teaching spaces that are un-lobbied and used in colder weather the heating system should have a fast response. Radiators are often used in primary school classrooms for this reason.

As cold outside air is denser than room air it can drop down onto the occupants and cause discomfort. Opening vents need to be sufficiently high, and distributed widely enough to prevent cold draughts reaching the occupied zone. There is a limit below which incoming air from high level openings driven by natural ventilation alone can mix with the internal air to prevent dumping of cold air onto the occupants.

⁴⁴ Technical Annex 21: ‘Controls’ to the EFSA Output Specification: Generic Design Brief provides the EFSA recommended specification for controls including recommended control strategies for ventilation systems.

Fan assisted mixing with room air before it reaches the occupied zone or a mechanical ventilation system with a heating coil or heat recovery can overcome the problem of cold draughts.

In order to reduce the problem of cold draughts, which often prevents the opening of windows in classroom spaces with low-level air inlets, the ESFA has developed guidelines for local thermal comfort and a 'Window and damper draught' calculation procedure.

See section 7.3.1 for the guidelines and for the description of the 'Window and damper draught' calculation required to assess the impact of cold draughts from high level natural ventilation openings.

4.10 The effect of wind and rain

The design should be capable of performing in the maximum wind speeds that are regularly experienced in the area. The maximum design wind speed can be taken as either 30 mph (13.4 m/s) or the 95th percentile wind speed taken from the local met office 4 km resolution weather map (which can be much lower than 30 mph in sheltered areas).

Some ventilation systems can lead to the pressurisation of a room by wind pressure to the extent that corridor doors become difficult to open. (A 30 mph wind equates to a wind pressure of 100 Pa on the facade).

4.10.1 Testing of dampers and weather louvres

Air leakage of dampers and thermal performance should be tested in accordance with BS EN 1751: 2014 or BS EN 1026: 2000.⁴⁵ Note: For practical reasons where large dampers are concerned, the requirement in BS EN 1751 for the face area of the test chamber to be 7 times that of the damper may be ignored.

External weather louvres should be provided to the appropriate weather and air flow ratings to prevent rain penetration as defined by BS 13030: 2001.⁴⁶

⁴⁵ BS EN 1751:2014 Ventilation for buildings. Air terminal devices. Aerodynamic testing of damper and valves. BS EN 1026: 2000 "Windows and Doors - Air permeability - Test method.

⁴⁶ BS EN 13030, 2001, Ventilation for buildings. Terminals. Performance testing of louvres subjected to simulated rain.

4.11 Building airtightness and thermal bridging

Low air infiltration rates prevent the uncontrolled ingress of contaminated outdoor air. The implications of 'airtightness' for building energy use, rather than ingress of air, are addressed in Approved Document L (AD L) (2013 in England and 2014 in Wales) of the Building Regulations.

AD L specifies minimum performance requirements in terms of air permeability. Air permeability is defined as the air leakage in m^3h^{-1} per metre square of building envelope area ($\text{m}^3\text{h}^{-1}\text{m}^{-2}$), which includes the ground-supported floor area, at a reference pressure of 50 Pa. Details on achieving and verifying performance are given in ATTMA publications⁴⁷.

External louvre and damper construction should consider thermal bridging and construction drawings should show the line of the thermal envelope.

Specifications should require manufacturers to test the air leakage and thermal performance of their louvre damper assemblies as described in section 4.10.1.

As modern buildings are very airtight it is essential to provide tempered make-up air for processes such as fume and dust extraction as part of the ventilation design.

4.12 Window design

The design of windows and associated blinds and shading devices affects ventilation and thermal comfort as windows let in solar gain as well as daylight and can be used as purpose provided openings for ventilation. They also provide views out and must be safe and secure.

The performance of windows can be compromised by their operation in use in a way that was not intended by the designer. For example, windows intended to be open at night for night purge may be locked for security reasons. This can be avoided through proper consideration of practical, health and safety and control issues at the design stage.

Window restrictors are required on some windows for security or to prevent hazards of pupils falling from upper floors or colliding with open windows at ground floor.⁴⁸

⁴⁷ ATTMA Technical Standard L2, Measuring air permeability of building envelopes (Non-dwellings), 2010.

⁴⁸ Detailed specifications for ESFA funded projects for window and door design are provided in the ESFA Output Specification, GDB, Technical Annex 2C: 'External fabric.'

4.13 Thermal mass and night cooling

Slab soffits in teaching and other densely occupied spaces will often need to be exposed to provide thermal mass to absorb heat and provide night cooling to prevent summertime overheating. This is particularly important in hotter locations such as urban heat islands. Heat islands are areas in cities such as inner London which have a lot of thermally massive buildings and roads which heat up and do not cool quickly overnight leading to day and night temperatures that can be much higher than surrounding suburban and rural areas.

4.13.1 Requirements for exposed thermally massive building fabric

In all areas where exposed thermal mass is used to prevent overheating it is recommended that the soffits should have a light surface with a visible light reflectance of more than 70% in order to achieve adequate luminance of the ceiling.

In teaching and circulation areas exposed soffits should normally be painted matt white. A white mist coat is usually adequate. Where a concrete soffit is painted, a high emissivity paint finish is required with emissivity >0.85 . These paints are easily obtainable from normal paint suppliers.

Where an exposed soffit is to be unpainted then the reflectance of the finished surface should be used in lighting calculations.

Any finishes to the soffit should not undermine the process of radiant heat exchange with the surface.

There is a balance of requirements with the need to provide sufficient acoustic absorption at high level to reduce the reverberation time of the space to achieve the correct acoustic environment for teaching. This will usually require some of the surface to be covered by acoustic absorbers or absorbers may be hung from the soffit.

If horizontal acoustic absorbers are used, it can be assumed that 30 to 40% of the soffit will be hidden by acoustic panels unless an acoustician advises otherwise. Radiant heating panels and lights can also obscure the soffit. This will reduce the cooling capacity of the soffit.

In naturally ventilated classrooms, the design should provide effective coupling of the ventilation air with thermally massive elements intended to provide passive cooling. The design should also prevent a layer of hot air being trapped at ceiling level in summertime leading to high temperatures at ceiling level.

One way to prevent this heat build-up is to provide sufficient high-level free opening area, eg at least 1.5% (of the floor area) as geometric free area, with the top of the opening within 200mm of ceiling level. This will significantly reduce the risk of summertime overheating of the room and excess asymmetric radiation from a warm ceiling. A forced air supply or extract at this level can also mitigate the heat build-up.

High-level vents as close as possible to the soffit can complement the need to get window heads as high as possible for good daylighting. Where concrete frame construction is used, avoiding down-stand perimeter beams makes this much simpler to achieve.

Walls and floors can also provide useful thermal mass. In order to use the thermal mass of the floor, carpet cannot be used, and a vinyl or similar floor finish is needed. Blockwork or flax-board walls can provide useful thermal mass but dry partitions are often preferred for walls. Some dry wall materials have some useful thermal mass however the primary design consideration is usually robustness. Thermal mass is a function of the specific heat capacity as well as the density and volume (ie mass) of the exposed material. Densities of similar building materials and their specific heat capacities vary considerably.

Designers should also consider the amount of display space and the degree to which display boards cover thermal mass.

4.13.2 Thermal mass and night purge

As adaptive thermal comfort is based on operative temperature, the use of heavyweight materials such as concrete soffits will have a positive impact on the calculations. However, there is limited benefit from such a strategy unless a night purge strategy is introduced to recharge the mass using cooler night air. The purge should be controlled automatically or limited to the start and end of the night to prevent over-cooling with subsequent reheat.

Night purge using fans can use a lot of energy and the volume flow rates are lower than is possible using natural ventilation and the stack effect. The Specific Fan Power (SFP) for night purge fans should be considered when conducting energy calculations. The SFP will vary depending on flow rate through systems. At night it may be favourable to increase the flow rate to increase the night cooling rate. The daytime flow rates will be limited by noise level and therefore fans may vary from day to night ventilation capacity.

Night cooling of thermal mass in ceilings should be controlled to prevent over-cooling of the thermal mass by means of room temperature feedback. It has been found that it can be effective to use room air temperature sensors with a self-learning algorithm

based on temperatures achieved on previous days. The alternative is to embed temperature sensors about 50 to 100 mm under the surface of the slab.

The security of night vents is important, particularly in ground floor rooms. The impact of night purge on intruder alarms, and nuisance tripping due to insects or movement of blinds should be considered.

When modelling night purge, the heating control set point temperatures should be such that the air temperatures do not drop below the minimum required for fabric protection. This will prevent over-cooling of the space, undesirable condensation effects and over-estimating the benefit of the night purge strategy. However, space temperature control set points should be reduced to take full advantage of night cooling during hot weather and to prevent the heating system coming on unnecessarily before occupancy during the heating season, see section 4.8.

4.14 Energy efficiency

The energy required to temper the outdoor air in the heating season can be a significant portion of the total space-conditioning load, increasingly so as fabric insulation increases. The heating of incoming ventilation air can represent between 20% and 50% of a building's thermal load, so should be limited to that needed for good indoor air quality. In the heating season, any outdoor air above that required for maintaining indoor air quality represents an energy penalty.

The design should wherever possible use the heat gains from occupancy and equipment and use this to warm incoming ventilation air.

Mechanical ventilation heat recovery (MVHR) systems, with the correct demand control can reduce heating loads by recovering the heat from internal gains. Room-based MVHR systems will need to have a minimum heat recovery efficiency factor of 75% to avoid the need to use a heater battery to achieve adequate supply air temperatures in a 100% fresh air MVHR system. The heat recovery efficiency factor should be measured in accordance with BS EN 308.⁴⁹ MVHR units should be able to maintain their specified efficiency at both low and high speeds. Although these systems use fan power to overcome duct resistance, filter replacements and ongoing maintenance; they have the benefit that they can provide good air quality in polluted areas when windows are closed.

⁴⁹ BS EN 308: 1997, Heat exchangers. Test procedures for establishing the performance of air to air and flue gases heat recovery devices

4.15 Climate change adaptation

The future proofing of the indoor environment of teaching spaces is important. The use of the BS EN 15251 adaptive thermal comfort criteria instead of the temperature threshold of 28 °C used in the previous edition of BB101 (2006) provides a more appropriate test for thermal comfort and a more resilient design in the event of climate change. The calculation includes August, which is not how schools are currently used and therefore provides an element of future proofing against climate change. In some locations it may be necessary to consider the urban heat island effect and some weather files make allowance for this, eg the latest inner city London weather files.⁵⁰

The planning of transitional and external spaces should consider climate change adaptation measures, to reduce internal temperatures and provide outdoor shelter. Transitional spaces range from unheated atria and covered walkways to more minor spaces, such as covered verandas and porches⁵¹. Whilst atria can be useful, overheating is a significant risk if atria are over-glazed with large horizontal glazed areas without appropriate shading and “landlocked” and have inadequate stack venting for summertime. See section 4.2.2 ‘Design of stack ventilation’.

Planting and structures such as canopies can provide shelter for outdoor space. Deciduous trees provide shade in summer. Canopies are usually provided for outdoor activities for early years and reception classes. Canopies are best offset from the building façade with a covered walkway connection at the doors. Canopies fixed to the facade may trap hot air and prevent the ventilation strategy from working especially in summertime and may reduce the amount of daylight reaching the classroom.

CIBSE KS16 contains useful advice about managing overheating in existing buildings. Designers should inform clients of measures to mitigate the overheating risk in areas prone to overheating such as lowering the night set point during summer (see section 4.13.2), scheduling the occupancy at cooler times of the day and relaxing the dress code. CIBSE publishes guidance on the design of buildings to take account of likely changes in future climate.⁵²

⁵⁰ TM 49 Design Summer Years for London, CIBSE, 2014

⁵¹ “Passive Solar Schools: A design Guide” includes a variety of transitional spaces, including examples of unheated atria and streets, and provides guidance on suitable depths of overhangs to prevent solar gain without unduly restricting daylight availability, DfE, Building Bulletin 79, 1994.

⁵² KS16 ‘How to manage overheating in buildings’ and other information on climate change adaptation is available on the [CIBSE](#) website.

4.16 Heating system selection, sizing and control

The heating system and heat emitters should be sized to:

1. overcome the thermal inertia of the building and any infiltration in order to achieve the required temperature at a reasonable time before occupation - with demand-controlled ventilation systems only infiltration needs to be included in the air load, provided the building is unoccupied during preheat
2. balance fabric and ventilation heat losses during occupation, allowing for the type of ventilation and heating systems and their control and the sensible heat gains to the space

Emitter temperatures can be increased during the warm-up period above temperatures required for thermal comfort where safe to do so. Care is needed if this is done in accommodation for pupils with special educational needs and disabilities (SEND).

If the ventilation system provides heat recovery then the ventilation losses should be calculated with reference to the temperature of the supply air.

Thermostatic radiator valves or similar control devices can be installed away from window openings to prevent heating more than the required quantity of outside air as a result of unmanaged windows.

All spaces should neither take too long to recover their temperature following sudden heat losses for example when external doors are open, nor overheat due to increased heat gains, changes in occupancy or equipment heat gain, or appearance of the sun. This can be a particular problem where underfloor heating is used and/or where entrance doors are not lobbied.

A lobby or buffer space is recommended on external doors to teaching spaces that are regularly used during the heating season, for example, in early years and infants classrooms. This excludes doors for occasional use, emergency exits and doors intended for use primarily in warmer weather. Fast response heat emitters should be used in spaces with outside doors.

4.17 Life cycle and maintenance

Life cycle and maintenance of heating and ventilation systems is an important consideration in the selection of equipment. Life cycle costs should include energy, cleaning and maintenance costs. Systems with low initial capital costs may have unaffordable running costs.

Fans, filters and heat exchangers should be easily accessible for maintenance and to inspect for contamination and easy to clean. Air handling units with filters should be fitted with remote indication of filter status. See section 6.5.2.

Air ducts and plenum spaces above ceilings that are used for ventilation should be accessible and cleanable.

4.18 Acoustic standards

Designs should meet the DfE acoustic performance standards for schools.⁵³ The main acoustic considerations are:

- Whether natural ventilation is a suitable strategy for the building taking into account the external acoustic environment - high external noise levels may preclude the use of systems based on free openings.
- If exposed concrete soffits provide passive cooling, the design should consider the reduction in the effectiveness due to acoustic absorbers and suspended ceilings that obscure the thermal mass.
- If ventilation paths are required through the building, the level of sound attenuation needs to be considered, eg between classrooms and atria.

4.18.1 Indoor ambient noise levels

Noise from building services including mechanical ventilation systems should meet the limits for indoor ambient noise levels (IANL) given in Table 1 of BB93 together with the tolerances on the IANL limits given in Table 2 of BB93 for different types of ventilation system under different operating conditions.

The design should show that IANLs can be achieved when the ventilation systems are operating in their normal condition; when providing intermittent boost ventilation; and when operating to control summertime overheating. A ventilation strategy may use one type of system for normal operation, and different types of system for intermittent boost and summertime overheating. Noise from ventilator actuators and dampers is covered in section 1.1.4 of BB93.

⁵³ Building Bulletin 93 'Acoustic Design of Schools: Performance Standards', Department for Education, 2015 gives the design criteria for acoustics in schools and 'Acoustics of Schools: a design guide', Institute of Acoustics and Association of Noise Consultants, November 2015 provides guidance on how to meet them. See References section Refs. 3 and 4.

5 Ventilation for particular areas and activities

This section gives the design requirements for particular areas and activities additional to those for basic teaching and learning described in section 2.4.

5.1 Office accommodation

Ventilation of offices should be in accordance with AD F, Table 6.1b, which, in the absence of excessive pollutants, requires the total outdoor supply rate to be 10 l/s/person.

This outdoor air supply rate is based on controlling body odours and typical levels of other indoor generated pollutants. AD F provides further guidance on the ventilation of office accommodation using natural or mechanical means. Local extract may be used as described in section 5.2.

5.2 Local extract ventilation

This section gives the requirements for extract ventilation, eg from toilets, washrooms, photocopiers and printers.

Extract ventilation should be taken to the outside and provided with appropriate time and occupancy controls.

Table 5-1 Recommended minimum local extract ventilation rates

Room	Local extract
<p>Rooms containing printers and photocopiers in substantial use (greater than 30 minutes per hour).</p>	<p>Air extract rate of 20 l/s per machine during use is required to eliminate pollutants. Air must be exhausted outside the building. If located in a separate room, it must be ventilated at the rate of 10 l/s/person when occupied as for an office. These rates are those given in AD F.</p> <p>Cooling is required to larger reprographics machinery often found in schools, (eg with heat loads of around 2 kW in use) where its use is intensive and it is located in a small room. This is due to the high heat loads produced which cannot be dealt with by extract ventilation. An alternative is to locate the machines in a circulation space, if there are no noise sensitive activities taking place in the circulation area, where the heat can dissipate.</p> <p>Photocopiers are often fitted with active carbon filters which limit ozone emissions. Some of these are sealed for life and others require maintenance. Information about the maintenance of photocopiers can be found in Local Authority Circular: LAC 90/2 ⁵⁴.</p>
<p>Sanitary accommodation and washrooms.</p>	<ul style="list-style-type: none"> • 6 l/s per shower head/bath; • 6 l/s per WC/urinal. <p>These rates are those given in AD F.</p> <p>Individual facilities can use intermittent air extract but combined facilities opening off circulation areas should have continuous extract with a peak rate of 6 l/s/appliance. A reduced continuous background rate of 4 l/s/appliance can be used where there is occupancy sensor control of the higher peak rate.</p>
<p>Cleaners' stores.</p>	<p>Extract ventilation should be provided to cleaners' rooms where there are sinks or where cleaning chemicals are stored. This can be added onto toilet extract systems where they are nearby.</p>

⁵⁴ HSE (2000) Local Authority Circular 90/2 online at [hse](http://hse.gov.uk)

Room	Local extract
Food and beverage preparation areas, eg in kitchenettes (not commercial kitchens or food technology rooms)	<p>Intermittent air extract rate of:</p> <ul style="list-style-type: none"> • 15 l/s with microwave and beverages to operate while food and beverages preparation is in progress. This rate is given in AD F. This is only required where these are located in individual rooms not where they are located in larger open plan office or circulation spaces <p>IGEM UP/11 guidance on gas safety should be consulted in preference to AD F for extract rates for gas cookers. IGEM UP/11 requires a minimum extract rate of 42 l/s (150 m³/h) per Type A Cooker. See section 2.9 on the gas safety regulations.</p>
Specialist rooms (eg catering kitchens, fitness rooms, science labs, food technology rooms).	<p>See section 5.4 on practical spaces.</p> <p>LEV includes fume cupboards and local exhaust hood type vent systems that remove pollutants at source.</p>

5.3 Atria, circulation spaces and corridors

If these spaces do not have enough ventilation or overheat it can affect the whole school and may result in uncomfortable conditions in teaching areas. See further guidance in section 4.2.2 'Design of stack ventilation'.

This section applies to circulation areas that are typically classified as unoccupied spaces. Where they include break-out and group spaces these should be ventilated for teaching and learning activities as described in section 2.4.

Corridors should be ventilated. This can be by opening windows or vents. The cold draught criteria in section 7.3 do not apply to corridor areas where the windows or vents are under local or manual control as these spaces are typically unoccupied. Where they include break-out learning spaces the cold draught criteria apply.

Corridors should not overheat in schools. Overheating usually occurs because they are "landlocked" and have very low ventilation rates so either this should be avoided or adequate ventilation should be provided. Overhead heating and hot water pipework should be well insulated to avoid overheating of corridor spaces.

Adequate ventilation and/or solar shading should be provided to prevent overheating due to solar gain from roof and wall glazing.

Heat gain into staircases should be considered. They may need to be ventilated to deal with high heat gains.

5.4 Ventilation of practical spaces

The ventilation of all practical spaces must be designed to provide adequate ventilation for the occupants. In addition, it should prevent the build-up of unwanted pollutants. In practice, general ventilation of the whole space can be provided to prevent the build-up of pollutants.

Local exhaust ventilation is often required to deal with a specific process, a heat source, or a pollutant source such as dust or fumes, that poses a risk to the health and safety of users or affects their comfort. In this case local exhaust ventilation may be considered to be necessary following a risk assessment carried out under the Control of Substances Hazardous to Health (COSHH) Regulations 2002.⁵⁵ Further guidance on local exhaust ventilation is given in sections 5.5 and 5.8.

Noise generated by extraction systems can be a problem. It should not be loud enough to prevent the teacher's voice from being heard by students, or the students' voice being heard by the teacher as this poses a significant hazard. If possible, it should be kept below 50 dB or (10 dB above the maximum Indoor Ambient Noise Level of 40 dBA) in accordance with section 2.21.2 of the *IoA/ANC Acoustics of Schools: a design guide, 2015*. Where this is not possible, higher noise levels of up to 55 dBA will only be acceptable where the teaching staff have control over the ventilation system and it can be switched off locally as required for teaching. Noise levels during normal teaching and practical activities should comply with section 1.1.3 of BB93. The minimum exhaust rates given in table 5-2 should be achieved within the noise levels given in BB93 section 1.1.3.

IoA/ANC Acoustics of Schools: a design guide, 2015 gives guidance on assessing and limiting the higher noise levels allowed during process related local exhaust ventilation such as use of fume cupboards or fume or dust extract.

Fans and ventilation systems specifically installed to remove hazards (eg fume extractors and fume cupboards) should not be controlled by emergency stop systems fitted to gas supplies and electrical circuits to isolate supplies in the event of

⁵⁵ Health and Safety Executive, Control of Substances Hazardous to Health (COSHH) Regulations 2002
- www.hse.gov.uk/coshh

accidents in science, food technology and design and technology spaces. However, the gas and electrical supplies within fume cupboards should be isolated by the emergency stop systems.

Ventilation rates in practical spaces for normal experimental conditions should be based on the minimum exhaust rates for pollutant control in table 5-2. At these rates the cold draught criteria in section 7.3 apply. The minimum exhaust rate is an area-based ventilation rate as used in ASHRAE 62-1-2013. Adequate make-up air must be provided. It may be a combination of outdoor air, recirculated air, and transfer air from an adjacent space depending on the activity.

Table 5-2 Minimum exhaust rates for science and practical spaces

Room type	Area (m ²)	Minimum required ventilation rate
Laboratories and preparation room	>70	4 l/s/m ²
Laboratories and preparation room	37-70	11.42 –(0.106 x Area) l/s/m ² [note that this is equal to flow rate for the room of 278 l/s]
Laboratories and preparation room	<37	7.5 l/s/m ²
Chemistry store room	All	2 air changes per hour, 24 hours a day.
Art classroom	All	2.5 l/s/m ²
Metal/wood workshop/classroom; Rooms with 3D printers; laser cutters; and spray booths for spray glue or spray paint aerosols	All	2.5 l/s/m ²

Note: Area-based ventilation rates in l/s/m² apply to spaces of 2.7 m height or higher. The equivalent air change rate per hour (ach) can be calculated from $ach = (l/s/m^2 \text{ rate}) \times 3.6 / (\text{Room height}(m))$. For spaces below 2.7 m in height the equivalent air change rate to a 2.7 m high space should be used.

Gas equipment in practical spaces shall be provided with adequate ventilation for safe operation. The levels of CO₂ shall also comply with the gas safety requirements and their limits of 2800ppm (warning level) and 5000ppm (shut-off level) of CO₂. See section 2.9.

5.5 Design and Technology

Design, installation and maintenance requirements for D&T rooms should comply with BS 4163: 'Health and safety for design and technology in educational and similar establishments'. BS 4163 provides a framework for the design and maintenance of Design and Technology (D&T) practical spaces in schools and describes the safety requirements for the range of machinery and activities. It also provides an up to date set of references to standards and regulations.

The three major concerns for D&T spaces are dust, fume and heat extraction. These pollutants can be present simultaneously.

D&T spaces should have a centralised air flow rate or the sum of the local extract flow rates of 2.5 l/s/m² when practical activities are occurring, see table 5-2. This should be controllable by staff. This area-based ventilation rate in l/s/m² applies to spaces of 2.7m height or higher. The equivalent air change rate per hour (ach) can be calculated from $ach = (l/s/m^2 \text{ rate}) \times 3.6 / (\text{Room height}(m))$. For spaces below 2.7m in height the equivalent air change rate to a 2.7m high space shall be used.

Local Exhaust Ventilation (LEV) should be provided for dust and fumes, subject to risk assessments.⁵⁶ Fume extraction is needed for but not limited to:

- hot metal work and heat treatment processes
- laser cutters
- 3-D printers
- surface cleaning and finishing and printed circuit board manufacturing (etching)
- soldering of circuit boards
- for some paints and adhesives, including spray fix as used in art rooms

Dust extraction is required for any dust that is produced including extract from portable power tools such as routers used in KS4 construction activities.

Wood dust extract is required. See section 5.9.

⁵⁶ See CLEAPSS Model Risk Assessments and CLEAPSS Guide G225 Local Exhaust Ventilation in D&T.

5.5.1 Laser cutters and 3-D printers

Harmful fumes containing nanoparticles and Volatile Organic Compounds (VOCs) can be produced by laser cutters and 3-D printers. They must therefore be housed in well ventilated rooms and provided with efficient fume ventilation systems.

There are two types of systems that can be used as shown in Table 5-3;

Table 5-3 Fume Ventilation Systems

Ventilation system	Description
Extract to Atmosphere (ETA)	Fumes are removed by negative pressure and discharged through an external flue above roof level
Filtration	Particulates are trapped in a HEPA filter and VOCs in a molecular gas filter. The clean air is returned into the room. These systems require regular maintenance and filter changes as recirculatory fume cupboards.

ETA is preferable as it needs less maintenance as there are no filters to change and performance should never decrease as long as the system is working correctly.

Filters should be changed regularly, the interval depending upon use and size of filter.

Both systems will require LEV tests at no more than 14 month intervals. In the case of recirculatory systems the tests will need to include measurement of filter effectiveness. The tests should measure whether harmful VOCs are being emitted and potentially returned to the inside of the building.

Further guidance on LEV equipment may be obtained from CLEAPSS and HSE.

Comprehensive detailed operator training at installation and afterwards is essential.

5.6 Food technology rooms

In all food rooms or food training areas and commercial or catering kitchens there is a need for extraction. This is to prevent the build-up of potentially harmful fumes caused by gas combustion and also to deal with heat gain, water vapour, oil, grease, pollutants and odours produced during cooking.

This section covers food rooms fitted with domestic type cookers used for practical work and demonstration limited to Type A appliances. School kitchens and vocational catering teaching spaces with larger commercial cooking ranges including

Type B appliances require more complex ventilation and interlocking of mechanical ventilation and gas supply systems. See section 2.9 and section 5.13 'Catering kitchens'.

Food rooms should be enclosed and not open plan to other teaching spaces in order to prevent dust from contaminating food. Make-up air should not be recirculated air or transfer air from another space.

Opening windows will require fly guards to prevent insect contamination unless there is mechanical ventilation providing filtered supply air. Fly screens are required where a ventilation system relies on natural ventilation openings at all times. In this case the resistance to air flow of the fly screens must be taken into account in calculations of effective area of openings. See section 8.3 on effective area of ventilation opening areas.

If refrigerators or freezers are kept in storerooms or kitchen areas, ventilation must be sufficient to maintain temperatures in accordance with manufacturers' recommended ambient temperatures for the siting of the equipment.

Some form of mechanical ventilation will be required in food technology and preparation areas at least some of the time. The room should preferably be kept under a slight negative pressure during cooking activities.

Mechanical ventilation systems must be interlocked with the gas supply. However, in school food rooms, where domestic ovens and or hobs are used (that are all Type A appliances, see section 2.9) the mechanical air extraction may not need to be switched on before the gas supply is available provided there is monitoring of the CO₂ levels within the space in accordance with section 2.9.2 'Gas safety interlocking by environmental/CO₂ monitoring'.

The teaching staff and teaching assistants must be able and aware of the need to energise the mechanical or extract ventilation system and open windows if the CO₂ levels increase above 2800ppm. Under these conditions the cold draught criteria in section 7.3 do not apply. New systems must isolate the gas supply to appliances if the CO₂ level increases above 5000ppm.

During normal cooking activities, noise generated by extraction systems should not be loud enough to prevent the students from hearing the teacher, or the teacher from hearing the students' voices, as this poses a significant hazard. If possible, it should be kept below 50 dB or (10 dB above the maximum Indoor Ambient Noise Level of 40 dBA required by BB93) in accordance with section 2.21.2 of the *IoA/ANC Acoustics of Schools: a design guide, 2015*. Where this is not possible, higher noise levels of up to 55 dBA will only be acceptable where the teaching staff have control over the ventilation system and can switch it off locally as required for teaching.

Noise levels during normal teaching and practical activities shall comply with section 1.1.3 of BB93.

Acoustics of Schools: a design guide, 2015, published by IoA and ANC, gives guidance on the higher noise levels allowed during process related local exhaust ventilation, such as from cooker fume extract systems.

Displacement ventilation systems, which extract the hot air from high level and supply cooler tempered air at low level, help to remove heat gains from the occupied zone and limit the ventilation rates required during cooking activities. For ventilation of domestic cookers in food rooms where there are up to 13 gas cookers in the space, there shall be minimum supply and extract of 42 l/s (150 m³/hr) of air per appliance, in accordance with IGEM/UP/11. This may be reduced where displacement ventilation of high effectiveness is used and a lower rate is shown to be adequate.

Exhaust ventilation may be in the form of individual extraction hoods or extract can be at high level from the space. Individual extraction hoods, if used, must not obstruct student sightlines to the whiteboard and noise levels will need to be considered. Where there are separate canopies above individual appliances, they should have a flow rate exceeding 42 l/s (150 m³/hr). This figure is inclusive of the 8 l/s required for CO₂ control.

In these spaces, the assumption is that appliances will never all be used at their full rate and will only be used with pupils for periods of less than one hour at a time. Mixed mode mechanical/natural ventilation systems rather than full mechanical ventilation systems will probably be the most economical solution.

Location of general room extract systems needs to be carefully considered to avoid excessive build-up of grease with provision made for ease of filter replacement and cleaning.

Whilst cookers and hobs are not in operation the ventilation standards should be as for a general teaching space, in accordance with section 2.4. However, during cooking, the levels of CO₂ given in section 2.9.2 must be achieved.

5.7 Science laboratories and fume cupboards

The general requirements for science laboratory and fume cupboard ventilation systems are to:

- a. remove contamination from the extract air caused by chemical processes

- b. provide background ventilation for the occupants
- c. ensure sufficient ventilation in areas where increased CO₂ and CO levels occur
- d. ensure sufficient ventilation for combustion

5.7.1 Design criteria

Science laboratories are often used for the majority of the time as conventional classrooms and shall be designed for such use, but require additional ventilation during experiments.

The ventilation design should address:

- e. the use of Bunsen burners
- f. chemical fumes produced during experiments
- g. the safe and effective use of fume cupboards

Table 5-2 gives the required minimum exhaust rates for various sized spaces. The rates for science have been adjusted to suit school science spaces in the UK and are the result of pollutant tests carried out by ESFA and CLEAPSS in science labs. The exhaust rates are needed during and following experiments and practical activities to clear the room of chemicals and other pollutants. CLEAPSS guidance including the model risk assessments for pollutants (including CO₂) generated by science experiments recommends that the quantities of chemicals used in experiments are kept to the minimum possible. If CLEAPSS guidance is followed in the use of chemicals the minimum exhaust rates quoted above are sufficient for normal occupancy and dilution of pollutants in school science.⁵⁷

Mechanical or hybrid ventilation systems should be used to provide adequate ventilation without cold draughts during teaching and practical activities in science laboratories unless it can be shown that the minimum exhaust ventilation rates given in table 7-3 can be provided by natural ventilation whilst meeting the cold draught criteria given in section 7.3.

In science laboratories a means should also be provided to increase the exhaust rate to at least 5 l/s/m². This can be by the use of openable windows and doors and by boosting the extract rate to a higher rate and a higher noise level under local

⁵⁷ CLEAPSS guidance is online at [cleapss website](#). CLEAPSS provide a national science and design and technology advisory service for schools.

override control of staff. This purge or boost ventilation allows staff to reduce any CO₂ levels or fumes in the room, eg following a difficult experiment, or a spillage, or if the CO₂ concentration reaches the warning level of 2800ppm. The cold draught criteria given in section 7.3 do not apply during purge or boost ventilation.

Noise levels during normal teaching and practical activities should comply with section 1.1.3 of BB93. The minimum exhaust rates for normal experimental conditions given in table 7-3 should be achieved within the noise levels for practical activities in BB93 section 1.1.3. Acoustics of Schools: a design guide, 2015, published by the IoA and ANC, gives guidance on limiting the higher noise levels allowed during purge or boost ventilation and the use of LEV such as fume cupboards.

The levels of CO₂ during practicals are permitted to rise higher than the limits for teaching and learning activities given in section 2.4, but must comply with the levels for gas safety given in IGEM/UP/11 and section 2.9.

5.7.2 Bunsen burners

Natural gas Bunsen burners as used in school laboratories typically produce up to 700 W, using 1.2 litres of methane per minute. If burnt with an adequate supply of oxygen this produces 1.2 litres of CO₂ per minute. Therefore if 30 Bunsen burners are in use in a laboratory at the same time, this would produce 0.6 l/s of CO₂. CO₂ levels can therefore be significantly elevated by the use of Bunsen burners; in a class of 30 pupils, CO₂ from 15 Bunsen burners is as high as that from respiration of 20 pupils.

Additional ventilation will be required when the whole class are using Bunsen burners or carrying out chemistry experiments that generate fumes.

5.7.3 Fume cupboards

Fume cupboards are needed in some laboratories and in chemistry preparation rooms. They should be installed and operated in accordance with CLEAPSS Guide G9 and British Standards. A risk assessment to HSG 258 is required for all fume cupboard installations.

Semi-mobile filtered fume cupboards (and where appropriate mobile filtered fume cupboards) must be easily connected by science staff by means of docking stations and quick release service connections. Ideally the connections should be set within the side of the teachers demonstration desk. The connections must not inhibit the safe use of the fume cupboards including for teacher demonstrations where students will need to gather round the fume cupboard.

The supply of incoming make-up air should compensate for extraction when ducted fume cupboards are in use. Note: Fume cupboards will generally balance themselves against supply and extract from natural ventilation paths in the same room, but can be adversely affected by the pressures generated by stack ventilation. With regard to mechanical ventilation that has a balanced supply and exhaust system, supply ventilation should increase to provide 90% of the fume cupboards exhaust rate when the fume cupboards are switched on so that the room is maintained at a slightly negative pressure.

Re-circulatory filtered fume cupboards are not recommended for use with carcinogenic or mutagenic chemicals some of which are used in schools.

Fume cupboards should where possible be of the ducted type. They should be fixed in position in preparation rooms. Semi-mobile ducted type fume cupboards, able to be pulled out from the wall on flexible connections, should be used in teaching spaces for demonstration purposes. The flues on semi-mobile ducted fume cupboards are designed to allow the fume cupboards to be pulled out from the wall while remaining attached to the external flue exhausting the fumes to atmosphere.

Exceptions where recirculatory fume cupboards may be used are:

- in refurbishments or remodelling where there is no practical means to run an external flue; or
- where the school require mobile fume cupboards in some teaching spaces - in this case, the following numbers of fixed ducted fume cupboards should be provided: at least one in the chemical preparation room, and at least one in a laboratory where the school teaches 'A' level science which should be a fixed or semi-mobile ducted type

Rooms where re-circulatory filtered fume cupboards are used should be ventilated to the minimum exhaust rate of 4 l/s/m² of floor area, given in table 5-2, whenever the fume cupboards are in operation, with facility to purge vent at a rate of least 5l/s/m² as described in section 5.7.1.

New re-circulatory filtered fume cupboards should comply with and be installed in accordance with BS EN 14175 standards for re-circulatory fume cupboards.

Where fume cupboards are in use, the air speed local to the sash should be as low as practicable. BS EN 14175 - 5 requires that the velocity of ventilation air should not exceed 0.2 m/s at a zone 400 mm from the fume cupboard.

Where experiments generate significant fumes a safe method of ventilation should be provided. This may include the use of a fume cupboard.

Normal fume cupboards are not designed for and should not be used to contain biological hazards such as bacteria cultures.

5.7.4 Preparation rooms

Ducted fume cupboards should be used in preparation rooms in preference to re-circulatory fume cupboards. If a re-circulatory fume cupboard is used in a preparation room, it shall have a vertical upwards discharge and the room shall have extract from high level to minimise pollutants in the occupied zone.

In chemistry preparation rooms, ventilation at the minimum exhaust rate should be continuous during normal working hours, with an override function for use out of these hours. Additional make-up air is required when a ducted fume cupboard is switched on.

Airflow rates will be high in small preparation rooms and air velocity could be more than the normal face velocity of a fume cupboard in the closed position. At such high airflow rates chemical fumes can be drawn out of the fume cupboard into the room. To avoid this a long air inlet slot and careful positioning of fume cupboards relative to windows and vents is needed in a small preparation room to keep the airflow velocities down in the vicinity of the fume cupboards.

5.7.5 Chemical stores

Chemicals used in science should be stored in dedicated chemical storerooms. Continuous extract ventilation should be provided 24 hours a day with make-up air at low level and extraction at high level. See table 5-2.

5.7.6 Ventilation controls

Air management systems with programmable controllers can accommodate a wide variety of room arrangements. Fume cupboard extract alongside room extract and supply should be controlled locally to ensure air flow rates are kept at acceptable levels for varying equipment and room usage.

Supply-and-extract systems providing the normal ventilation rate, ie when the ducted fume cupboards are off, should reuse the heat from the room by mixing or heat recovery to minimise ventilation heat losses.

Black-out blinds required for physics experiments can interfere with natural ventilation paths, and therefore this needs to be taken into account when designing a ventilation system. During black-out experiments the ventilation rate can be relaxed to 5 l/s/person.

5.7.7 Fume cupboard exhausts and building exhaust design

Exhausts from fume cupboards should discharge at a safe height above the highest part of the building. BS EN 14175-3 gives recommendations on the installation of fume cupboards. It recommends that the discharge should be at 1.25 times the height or 3 m above the highest point of the building and the minimum efflux velocity should be 7 m/s or preferably 10 m/s. Where flues are lower than recommended the efflux velocity will need to be increased to overcome downdrafts.

ASHRAE Handbook – ‘HVAC Applications’ states that downdrafts do not occur when the efflux velocity is high enough. This is the reason why a minimum efflux velocity of 15 m/s is often used for fume cupboards and commercial kitchen exhausts.

Further guidance on fume cupboard discharge is available in ANSI/AIHA Z9.5, 2003, ‘American National Standard for Laboratory Ventilation’. The standard advises that:

- a discharge velocity of 12.7 m/s (2500 fpm) prevents downward flow of condensed moisture within the exhaust stack
- it is good practice to make the terminal velocity at least 15.2 m/s (3000 fpm) to encourage plume rise and dilution

Appendix 3 of the standard gives advice on the various calculation and modelling procedures available for stack sizing including those in the ASHRAE Handbook – ‘HVAC Applications’, Chapter 45 ‘Building Air Intake and Exhaust Design’. The ASHRAE ‘Applications Manual’ gives further advice on stack design and equations for the geometric stack design method and the exhaust to intake dilution calculation. These equations may be used to calculate stack heights and efflux velocities where a flue of the recommended height of 3 m is not possible, eg in the case of planning restrictions. The primary reason for the minimum height of 3 m is to protect workers on the roof and if lower stack heights are used, barriers and management procedures need to be in place to protect workers on the roof.

CIBSE TM 21 ‘Minimising Pollution at Air Intakes’ gives further information on calculation and modelling methods but the calculation methods used should be those in the ASHRAE ‘Applications Manual’⁵⁸ as these are frequently reviewed and may have been updated since the publication of TM 21.

⁵⁸ ASHRAE Handbook - HVAC Applications, in Chapter 45 on Building Air Intake and Exhaust Design

5.8 Local exhaust ventilation systems

Guidance on LEV systems in design and technology spaces is given in BS 4163.⁵⁹

BS 4163 does not specify the type of LEV systems to be used but requires risk assessments to be carried out to decide this. It is essential that risk assessments to determine the need for LEV in D&T and the choice and provision of suitable LEV are based on professional advice.⁶⁰ HSG 258 provides more detailed information on LEV systems and legal competency requirements.⁶¹ H&S requirements apply equally to both stand alone LEV systems and machine based extract systems.

Wherever dust is produced, a risk assessment must be undertaken and, if necessary, a control measure shall be put in place, including for the emptying and disposal of dust from LEV systems.

Local exhaust ventilation will be needed for most of the following applications:

- cooking appliances that give off steam, oil, grease, odour, and heat and products of combustion
- equipment for heat treatment, including for brazing, forging, welding, and soldering
- woodworking machines, including for sawing, sanding, planing, and thicknessing
- chemical processes, including acid pickling, plastics work, paint spraying, and engine exhaust emissions
- working with adhesives
- metalworking machines
- polisher or buffing machines - these often require some form of LEV to trap and extract fibres and polishing compound (grinders less often)
- work undertaken with plastics and glass reinforced plastics (GRP)
- most CNC (Computer Numerical Control) machines have LEV, usually integral to the device - some have an auto cut-off switch to prevent the machine from running if extraction is not on
- 3D printers, laser cutters
- photocopiers

⁵⁹ British Standards Institute (2007) BS 4163 Health and Safety for Design and Technology in Schools and Similar Establishments – Code of Practice (AMD 11025), Revision to be published in 2014. London: British Standards Institution Bookshop. BS4163 is currently under revision and will be going to public consultation imminently – the final version should be published in September this year.

⁶⁰ CLEAPSS, The Design and Technology Association (DATA) and The Institute of Local Exhaust Ventilation Engineers (ILEVE) provide advice on design, operation and maintenance of safe systems for Science and Design and Technology including Local Exhaust Ventilation.

⁶¹ HSG 258 'Controlling airborne contaminants at work, a guide to local exhaust ventilation (LEV)', 2011 is online at the HSE [website](#)

Important points to consider are:

- combustible dusts (eg fine particles of wood, plastics and some metal dusts) should be separated from those produced in processes where sparks are generated - the risk is that a hot metal spark can become embedded in wood dust, and smoulder for some time, then ignite when the LEV system injects a flow of outdoor air
- it is necessary to avoid creating hazardous waste by the mixing of dusts
- the local exhaust inlet should be sited as close as possible to the source of contaminant, depending on the design of the machine, and extracted to a place, which will not cause harm
- the risks from emptying and servicing or maintenance need to be considered. The person emptying the system can inadvertently be exposed to much higher levels of dust than the operators through poor LEV design
- air needs to be brought into the space to compensate for air exhausted to the outside - this make-up air may need to be heated in order to maintain adequate internal conditions

Computer-aided manufacturing (CAM) and CNC machines require their own extraction systems. Some machines such as CNC routers and the extract systems can be very noisy and cause disturbance, since they are often left running during other class activities. Sometimes the problems associated with local extracts can be dealt with by a remote extract fan and associated filtration. This can reduce noise and be more space efficient.

CLEAPSS⁶² produces risk assessments for pollutants commonly used in science and D&T. The CLEAPSS Model Risk Assessments for Design and Technology define ventilation needs for many D&T processes. The CLEAPSS hazards specify a 'well-ventilated room' for science labs see section 5.7.1. The CLEAPSS requirement for a 'well-ventilated room' may also indicate a need for local extract, or exhaust ventilation. For example, a cooker hood may be needed over a hob or a fume hood or fume cupboard when handling chemicals.

LEV systems and specifications should comply with HSE guidance including HSG 258⁶³. LEV risk assessments and specifications should identify the processes, contaminants, hazards, sources to be controlled and exposure benchmarks.

⁶² CLEAPSS See www.cleapss.org.uk

⁶³ HSG 258 "Controlling airborne contaminants at work, A guide to local exhaust ventilation".

Exposure benchmarks should be based on EH40⁶⁴ and on CLEAPSS guidance on risk assessments for Science and D&T.

Make-up air should not create draughts or disturb the airflow into LEV hoods and fume cupboards. Ventilation openings should be designed to minimise such effects and they should be sited away from LEV hoods and fume cupboards.

LEV systems in work areas will fall under the Control of Noise at Work Regulations, which requires action to be taken to minimise exposure to noise. Noise is often a concern with LEV whether installed locally to a machine or as a central system.

LEV systems should be designed to minimise noise levels so that indoor background noise levels do not disturb educational activities. Where possible, extract ducts should be run in bulkheads or above suspended ceilings to minimise noise in teaching spaces. Fans should be positioned remotely from the rooms served, both for acoustic reasons and to place as much ductwork as possible under negative pressure.

It is recommended that the noise level in teaching spaces due to LEV equipment related to teaching activities should be kept as low as possible so that it does not interfere with the teaching and learning activities⁶⁵.

Extract air from laboratories and similar spaces should be ventilated directly to the outside and not to other spaces.

Calibrated airflow indicators must be fitted to all new LEV systems to allow an easy way of checking that the LEV is working. An indicator or alarm should also be fitted to show if filters have blocked or failed. This can be by means of a manometer or a BMS alarm from a pressure sensor. Monitoring records should be kept and recorded as per the installation requirements and as indicated by risk assessment.

A user manual and health and safety logbook should be provided for every LEV system. This should specify the recommended level of training qualification required for operators who carry out maintenance on the LEV systems.

Clear management systems and proper, safe work routines including the use of PPE shall be included in operation and maintenance manuals and health and safety log books.

⁶⁴ EH40/2005 "Workplace exposure limits"

⁶⁵ Guidance on noise levels is given in the Acoustics of Schools: a design guide, November 2015, the Institute of Acoustics (IOA) and the Association of Noise Consultants (ANC).

The design and installation of the LEV systems should be included in the CDM Health and Safety File⁶⁶ and Operation and Maintenance documents. The level of maintenance will depend on the frequency of use of the LEV equipment.

The designer should ensure that:

- LEV systems are designed by qualified professionals
- LEV systems are supplied with performance data on installation - this should include filter efficiencies - this is necessary so that subsequent testing can be compared with the performance on installation
- all LEV systems across the D&T and science departments should have a 'Thorough EXamination and Test' (TEXT) every 14 months – this should be carried out by a competent person – usually an external contractor - details of the statutory 14 monthly LEV equipment TEXTs should be included in the O&M manual, the H&S file and the Building users guide - the checking of the extractor units on laser cutters, fume cupboards and other equipment should be included in the TEXTs
- a logbook is provided to record the results of the commissioning and 14 monthly performance TEXTs and the H&S file tests
- Workplace Exposure Limits (WEL) for wood dust (see section 5.9) should be recorded in O&M Manuals and the H&S file and procedures defined to keep levels as low as reasonably practicable
- the O&M manuals and H&S File must contain manufacturers and designers' maintenance schedules to ensure the systems perform as designed

The Institute of Local Exhaust Ventilation Engineers (ILEVE), a Division of CIBSE, provides access to competent local exhaust ventilation engineers and accredited training for those who maintain the equipment. See references for further information sources and useful guidance on LEV.

5.9 Wood dust extract systems

Wood dust can be hazardous and needs to be cleared and filtered from the air.

There are two types of dust collection systems:

- centralised dust extraction
- smaller local LEV units

In choosing where to employ these systems it is very important to consider the actual circumstances of a modern teaching and learning environment. According to

⁶⁶ The Construction (Design and Management) Regulations 2015

BS 4163 the need for an LEV system is decided following a risk assessment and the BS does not define which type of system is preferred.

Wood dust extract systems vary greatly. The issues are complex and in differing schools, different solutions will be appropriate. In some cases, a mixture of a centralised system for the Prep room and the more heavily used machinery and the sweep-up points, with additional local LEV to other machines, is the best option. The advantages of well-designed centralised LEV systems are that they can be:

- effective in capturing wood dust
- low noise
- easily maintained
- cost effective with low running costs and low energy costs
- provide a single collection point for all the dust generated.⁶⁷

However, in some schools with badly designed central systems; excessive noise reverberating throughout all workshops occurs. The result is significantly reduced quality of teaching and learning. The reality of intrusive noise caused by some centralised systems is that many schools seek to remove them and replace them with more flexible, local solutions. The noise nuisance to near neighbours must be considered, particularly in residential areas. Design for noise control, eg using low friction bends, is therefore very important. In some cases to reduce noise it is necessary to fit variable speed drives and automatic valves to open and shut dampers and machines may need to be interlocked with the LEV system so that they cannot be started without the LEV running.

Guidance on operational noise is given in section 2.21 of Acoustics of Schools – a design guide, 2015, published by the ANC and the IoA.

5.9.1 Centralised systems

Centralised systems are ideal for material prep rooms, vocational training and site team workshops. Centralised systems with fixed ducting are relatively inflexible as it is not easy to change the layout of machines and equipment. However, Low Volume, High Velocity (LVHV) LEV centralised systems with low noise levels are suitable for modern, flexible design and technology workrooms.

Centralised dust extract systems to woodworking machinery should be designed so that:

⁶⁷ See the HSE [website](#) for a case study comparing different types of installations in two schools.

- the dust collection unit and extract fan are located so that the unit can be used quietly and can be easily and quietly emptied without disturbing class activities - this unit should ideally be located in a separate room - sometimes this can be the prep room but it is better to locate this unit in its own room to contain the noise and dust - the shaker and fan and main branch ducts can also be located in this space so that noise ingress into teaching spaces is minimised
- the air inlet to the plant room is acoustically attenuated to prevent noise causing significant disturbance to teaching areas via open windows, and to outside areas
- vacuum hose connections are provided, instead of having a 'sweeping up' arrangement, and inertia type reels for vacuum hoses are provided in the preparation room and the students' work area
- automatic fire dampers are provided in the dust extract system and the associated plant room
- the system is fitted with a variable speed fan and machinery dampers and interlocks, so that the system changes the flow rate when machines are switched on and off and allows hand tools to be connected - the interlocks provide automatic shut off of the extract system when the waste bag is full and a warning is provided to the prep room when the bag is nearly full
- all branch ducts are designed for low resistance as described in HSG 258

5.9.2 Local systems

Systems local to individual machines should either be interlocked with the machine so that they will not start without the LEV running or provided with a local switch adjacent to the machine.

5.9.3 Design of dust extract systems

The HSE has observed many poorly designed dust extract systems in schools that are not able to do the job required and the teaching staff and students have to work in conditions in which dust is not adequately controlled.

The use of legacy equipment is a way of keeping costs down. However as local systems have often 'developed' over time, when these are carried over to a new building they can often be found to be inadequate, especially compared to newer, carefully designed systems.

All systems will need to filter the recirculated air to a safe level. In order to do this careful specification of flow rates and methods of particle capture as well as filter

characteristics is required. The type of materials being used and the frequency and duration of the activities must be considered in the Risk Assessment.

If dust is produced, a Risk Assessment must be undertaken and if necessary some control measure should be put in place, this includes when the LEV systems are emptied. The risk to teaching staff and students can be significantly increased when emptying local systems. This risk must be managed.

Emptying and disposal of dust from LEV systems must be considered at the design stage. Clear management systems and proper, safe work routines including the use of PPE should be included in operation and maintenance manuals and health and safety logbooks.

CLEAPSS consider any dust to be a hazard regardless of what is being cut, if it creates dust it needs to be controlled if the risk assessment determines this.

The CLEAPSS Guidance Document L225⁶⁸ is based on published advice from the HSE, visits to school and college workshops (where measurements were made with a dust monitor and photographs taken using a dust lamp) and discussions with experienced health and safety advisers. See table 5-4 adapted from CLEAPSS Publication L225.

⁶⁸ CLEAPSS guidance L225 - LEV in Design and Technology (March 2003)

Table 5-4 Types of dust extraction

Table adapted from CLEAPSS Publication L225

Type	Characteristics	Noise	Advantages	Disadvantages
Fixed installations for whole area serving several machines	<ul style="list-style-type: none"> a. Inlets at each machine or dust source, preferably with dampers that can be closed when the inlet is not in use. b. Fixed ducting. c. A fixed filter or dust- collection system. d. A single fan unit. e. An outlet that might return air to the workplace or vent it to the outside. f. Dust collection unit and fans may be in the room, or in a separate room or in an external enclosure with ducting to the equipment. g. Unit may serve more than one room. h. Warning system required to tell user when dust collector needs emptying. i. Units and are best located in a separate space or external to the building for ease of maintenance and to limit noise. 	<p>Depends on design. Sound levels greater than 80 dB (A) caused by fixed flow rate make verbal communication difficult.</p> <p>Where the noise exceeds 80 dB (A) ear defenders are required. New installations should not have noise levels requiring ear defenders.</p> <p>Noise can cause distractions to the teaching environment and to neighbouring buildings, depending on location.</p> <p>Noise can be limited if unit is variable speed and housed in separate space. Also by good quality ductwork with smooth bends.</p>	<p>Single point of dust collection makes dust handling and maintenance easier and safer - only one filter to clean or replace.</p> <p>The noise is low if the fan is outside the workplace and the duct does not carry sound.</p> <p>Low running costs due to single point of maintenance</p> <p>Low energy costs if variable speed.</p>	<p>Fan and filter units are large and need to be in a sound proof enclosure.</p> <p>High noise levels if the system is located in the workplace and/or if the duct velocity is too high or ductwork poorly designed so that it transmits sound. This may lead to ambient noise problems in rooms where quiet is needed.</p> <p>Extra electrical controls are required to ensure that the system starts up when any machine is in use and to vary the air flow according to the number of machines in use.</p> <p>Users will need training to operate dampers and controls.</p> <p>If the extraction unit fails, none of the machines connected to the system can be used.</p> <p>Relative inflexibility to easily move machines or connect and disconnect machines.</p>

Type	Characteristics	Noise	Advantages	Disadvantages
Independent installations at each machine	<p>a. Fan unit is close to the machine producing the dust.</p> <p>b. Fan and machine are often electrically linked, so that the fan is powered whenever the machine is running.</p> <p>c. For dust control, the filter / dust-collection system is normally mounted in the same unit as the fan.</p> <p>d. Warning system required to tell user when dust collection needs emptying.</p>	Can be a problem unless each fan unit is very quiet.	<p>Units are often compact, being designed to fit under the bench or into the pedestal supporting the machine.</p> <p>Automatic starting of the dust control is easy.</p> <p>Failure of one unit does not affect use of any other machine.</p>	<p>Many dust-collection bags and/or filters to attend to.</p> <p>Many fans can generate much noise.</p> <p>Dust collection units must be changed in an occupied space.</p> <p>The relatively small filter area and size of unit can result in the filter becoming clogged and hence a lack of efficiency.</p> <p>Dust collection capacity can be small requiring regular emptying.</p> <p>These units are unlikely to cope with large volumes of waste such as those produced by wood planing machines.</p>
Portable systems	<p>A mobile duct, filter, dust sack and fan unit, which can be moved between machines.</p> <p>The inlet may be general purpose or part of each machine.</p>	A serious problem unless each fan unit is very quiet.	An economical solution for a workshop containing several machines with intermittent use.	<p>General-purpose units are not always efficient and may not adequately control contaminants. Dust capture hoods may be ineffective unless designed for each machine.</p> <p>Difficult to make system and machine electrically interlocked. It is then debatable whether or not the system fulfils legal requirements.</p> <p>There is a high risk that LEV may not be used because of the effort of connecting up.</p> <p>Difficult to empty and connect and reconnect safely.</p>
Extraction from portable power tools	A very flexible duct connected to a stand-alone dust collector or a small dust bag connected to the tool.	Portable power tools are often noisy anyway and the extra noise associated with the dust-collection system may be trivial.	Good for vocational training as this is the usual method of extraction found on site...	<p>The dust-collection system may make the tool difficult to control.</p> <p>If a small dust bag is fitted, it can be filled after only a few minutes work and must be changed or emptied frequently.</p> <p>Dust capture may not be effective enough for indoor use.</p> <p>This type of system will not usually effectively protect others nearby unless used in a very well ventilated space or an external workspace. If used inside PPE will probably be needed for those nearby as well as the user.</p>

Purchasing off-the-shelf units and having them installed by a technician is not recommended.

5.10 ICT-rich teaching spaces

Heat gains from information and communication technology (ICT) equipment may be useful in the heating season, but can lead to overheating in the summer. Heat gains can be minimised by selecting energy efficient appliances with low heat rejection.

It should be possible to avoid overheating in the majority of ICT-rich teaching spaces through good natural and hybrid ventilation system design without the need for mechanical cooling with the appropriate thermal construction and measures to minimise solar gains.

With an appropriate control strategy, for most of the year, mechanical cooling should not be needed. Passive cooling methods can accommodate most ICT loads but may be more costly than mechanical split system cooling units. However mechanical cooling has high maintenance and energy running costs. If ICT-rich rooms can be located on the north facade or where greater stack heights can be achieved this will increase the effectiveness of natural ventilation for cooling.

In classrooms with more than the typical provision of ICT equipment, mechanical ventilation and comfort cooling may be needed for peak lopping in the hottest summertime conditions.

5.11 Sports halls and main halls

Main halls are often used for more than one activity. Some are used for occasional activities, eg performances once a year in primary school halls. In these cases as the events are fairly infrequent it may be that standards can be relaxed slightly.

For the majority of the time there may only be one or two class groups in many halls, eg 30 to 60 students using the space and much less outdoor air will then be needed to maintain the required CO₂ levels. The CO₂ rates from section 2.4 (for general teaching and learning spaces) apply also to halls.

Secondary schools use their sports halls for a range of sporting activities and they typically also use the sports hall for public exams because it can accommodate a whole year group at one time; the environmental conditions need to allow for this. Splitting up the year group and using other spaces such as the main hall and smaller PE (physical education) and drama spaces may be possible in some cases but is far more difficult for schools to manage. The environmental standards for sports halls are summarised in table 5-5.

Table 5-5 Environmental standards for sports halls

Design parameters for sports halls		
	Normal maintained operative temperatures (°C) (from table 7.2)	Thermal Comfort
Sports (General)	17	Overheating Risk Assessment (ORA) (See section 7.6) to Category III for sports use, (See table 7.8)
Examination	20	ORA to category II for the examination occupancy profile, (See table 7.8)

The designer should ensure that the overheating assessment and dynamic thermal modelling uses a reasonable occupancy profile. This will ensure that ventilation systems are sized correctly. The examination period, for the purpose of the Overheating Risk Assessment, for a secondary school hall shall be taken as weekdays 09:00 to 16:00 from 1st May to 8th July with a lunch break as described in section 8.1.

Noise levels are important during examinations and some heating and ventilation systems may be too noisy, eg gas fired radiant heating with the burner in the space. Radiant heating can be used effectively in sports halls but the radiant temperature asymmetry (RTA) will need to be considered. See section 7.4.

5.12 Ventilation in special schools and designated units

It is advisable to minimise recirculation of air in areas for children with complex health needs. This reduces the risk of cross-infection and the circulation of allergens.

Laundries, soiled holding or waste, and cleaners' rooms should be ventilated by means of mechanical extract with natural or mechanical make-up air.

Toilets for students with complex health needs and hygiene rooms should be ventilated by means of mechanical extract to outside, with make-up air, heated and filtered.

Toilets, showers, hygiene rooms, laundries, cleaners' rooms and spaces holding soiled clothes or clinical waste should be mechanically ventilated. The systems should provide a slight negative pressure relative to adjacent spaces.

Ventilation design should not compromise acoustic performance, particularly where students have additional sensitivities to noise.

5.12.1 Infection control

For schools where there are students with complex health needs, ventilation systems should be designed for infection control and to maintain standards of hygiene. Teaching staff/assistants should be able to control ventilation for comfort. Draughts should be minimised so as not to affect vulnerable and immobile students.

Legionella is a higher risk to people with complex health needs some of whom may be immuno-compromised. Particular attention needs to be paid to legionella prevention in domestic hot water systems and in any adiabatic cooling systems in these schools⁶⁹.

Where mechanical ventilation is specified filtration should be provided, depending on external air quality and design exposure levels, see section 6.5.2.

The requirements for ventilation for mainstream schools are based on a typical occupant density of 30 students and one or two staff per teaching space. The occupant density for special schools is much lower so a design rate per person is not appropriate, although the general guidance on ventilation applies. The minimum requirements for ventilation for hygiene and air quality are summarised in table 5.6.

Ventilation systems should be controllable and adjustable, according to the needs of individual students. Air conditioning should be avoided but where present should be regularly maintained to minimise noise emissions and to maintain hygiene conditions.

⁶⁹ See CIBSE TM13 and HSE L8 Legionnaires' disease. The control of legionella bacteria in water systems

Table 5-6 Ventilation for special educational needs and special schools

Space	Minimum ventilation rate	Ventilation mode - mechanical /natural/hybrid
Teaching spaces, medical and sick rooms and changing areas	2.3 l/s/m ² or 8 l/s/person whichever is the greater; when occupied.	Ventilation should be capable of controlling internal temperature and draughts. Sick rooms should be provided with full fresh air with no recirculation.
Specialist teaching spaces	Supply air should be sufficient to replace process-extracted air, control internal temperature and control odour/CO ₂ . Extract air should be sufficient to meet requirements for fume, steam and dust removal and to control internal temperature and CO ₂ .	Natural, hybrid or mechanical with Local Exhaust Ventilation and fume cupboards if required.
Toilets, showers, hygiene rooms	7.5 l/s/m ²	Mechanically extracted to outside, provision should be made for make-up air, which should be heated and filtered. The systems should be separate from any general school ventilation system.
Laundries, soiled holding or waste, cleaners rooms	3.8 l/s/m ²	Mechanical extract with provision for natural, hybrid or .mechanical make-up as appropriate
Halls, gym, dining, physiotherapy	Dependent on density of occupation, but based on 8 l/s/person or 2.5 ach whichever is the greater, when occupied.	Ventilation should be sufficient to limit CO ₂ and control odours.
<p>Note: The area based ventilation rates in table 5-6, in l/s/m², apply to spaces of 2.7m height or higher. The equivalent air change rate per hour (ach) can be calculated from $ach = (l/s/m^2 \text{ rate}) \times 3.6 / (\text{Room height (m)})$. For spaces below 2.7m in height, the equivalent air change rate to a 2.7m high space shall be used.</p>		

5.12.2 Managing cross-infection

Some students in special schools may be very vulnerable to infection. In these cases Health Technical Memoranda, specifically HTM 03-01 Part A⁷⁰, published by NHS Estates should be consulted and it is essential that infection control policies are in place and implemented. Managing cross-infection is a complex subject, but the risks of cross-contamination can be reduced through adequate source control.

⁷⁰ Health Technical Memorandum 03-01: Specialised ventilation for healthcare premises Part A: Design and validation

5.13 Catering kitchens

This section covers school kitchens and vocational food rooms for teaching catering where the equipment in use is similar.

The design of the kitchen ventilation system should be generally in accordance with DW 172.

Flue heights and efflux velocities and odour control should be either in accordance with DW 172 or the local planning requirements for commercial kitchens. See also section 5.7.7.

Maximum internal ambient noise levels should be in accordance with BB93.

The designer should use the method set out in DW 172 for calculating the required extract air flow rate for the kitchen canopy or for a ventilated ceiling.

Dedicated supply make up air systems should be designed at 85% of the extract flow rate and leakage paths need to be properly managed.

The designer should use the method set out in BS 6173 in order to calculate the required ventilation to support combustion for gas appliances.

The designer should ensure that:

- a. sufficient ventilation is provided to safeguard against the possibility of incomplete combustion
- b. an interlock is provided between gas supply and mechanical ventilation to ensure that gas will not be supplied when an inadequate airflow rate is provided - this is for safe operation of appliances and the safety of personnel
- c. the system is fully compliant with the requirements set out in IGEM UP 11 "Gas Installations for Educational Establishments", IGEM UP 19 and the requirements for gas services set out in section 2.9
- d. the system does not cause discomfort to the occupants via draughts - the incoming supply air shall be pre-heated and distributed within the Kitchen area in accordance with DW 172
- e. the discharge from the exhaust of the system is appropriately positioned

- f. the discharge from the exhaust of the system does not cause discoloration or damage to any part of the building structure or any noise or odour problem to neighbouring rooms or properties
- g. maintenance and cleaning schedules are included in O&M manuals and a kitchen user guide is produced as part of the Building Users' Guide

HSE Catering Information Sheet 23 details the risk assessment process that designers should use for refurbishment and upgrading of existing installations that do not meet the requirements for new installations.

The HSE guidance note on ventilation of kitchens in catering establishments applies to food technology rooms as well as school kitchens⁷¹.

The Food Safety and Hygiene (England) Regulations 2013, require that opening windows in commercial catering kitchens are fitted with fly-screens to prevent insect contamination. Fly-screens are required unless there is mechanical ventilation that can provide filtered supply air at any time.⁷² Fly-screens are also required where a ventilation system relies on natural ventilation openings at all times. The resistance to airflow of fly-screens must be taken into account in calculations of effective areas of openings. See section 8.3 on effective area of ventilation opening areas.⁷³

If there are refrigerators or freezers in storerooms or kitchen areas, there must be enough ventilation to maintain manufacturers' recommended ambient temperatures for the equipment.

Pre-heating of the ventilation air may be needed due to the high ventilation rates required in these spaces. Heat recovery can be cost effective when a balanced mechanical ventilation system is used.

Energy consumption of kitchens and their ventilation systems varies greatly depending on the specification of kitchen equipment and its ventilation requirements. See CIBSE TM 50 *Energy Efficiency in Commercial Kitchens* for guidance on energy efficient design and benchmarks.

⁷¹ Health and Safety Executive (2000), *Catering Information Sheet No 10*, online at [hse publications](#) and Health and Safety Executive (2000), *Catering Information Sheet No 11*, online at [hse publications](#)

⁷² Online at the [gov.uk legislation website](#)

⁷³ The Food Safety (General Food Hygiene) Regulations 1995 are online at the [legislation.gov.uk website](#)

5.13.1 Grease filters and odour control

Grease filters, preferably of the removable baffle type, should be installed so that they are accessible for cleaning and maintenance. Grease extracted by the ventilation system should be collected and removed so that it does not accumulate in either the canopy or the ductwork system.

Cooking odours can be generated as a product of the combustion of animal and vegetable matter which results in a particulate and gaseous mixture. These molecules can be too small to be removed by filtration.

DW 172 and Defra guidance⁷⁴ summarise the available odour control and filtration and noise control technologies along with their advantages and disadvantages. The priority should be to provide simple technologies that are easily maintained by school staff and to provide adequate efflux velocity and flue height to provide good dispersal rather than to employ expensive odour control and filtration systems with a lower flue height and efflux velocity. Wherever possible flues should terminate at least 1 m above the roof or any air inlet with an efflux velocity of at least 10 m/s as recommended in DW 172.

5.14 Dining areas

The smell of food from dining areas can be a nuisance. The transfer of air from dining areas to the other parts of the school should be avoided. This can be a particular challenge when atria containing food areas are linked to large areas of the school. The main dining areas and the kitchen should be under negative pressure. It is often possible to extract from dining areas through the kitchen. The requirements for acoustic separation between the kitchen and dining area when used for other activities, during the day, for example, in a multi-purpose hall should be met.

5.15 ICT Server rooms

Server rooms can produce high density heat loads which can affect Information Communications Technology (ICT) equipment. The ventilation system and cooling strategy will depend on the heat loads and the type of equipment.

⁷⁴ Guidance on the Control of Odour and Noise from Commercial Kitchen Exhaust Systems, DEFRA, 2005.

Equipment operating temperatures and noise levels from equipment will need to be considered. Environmental conditions should be in line with the manufacturer's recommendations and any warranty requirements of the equipment.

Modern UPS systems and server room ICT equipment should be capable of operating in an A3 classification environment as defined within ASHRAE TC 9.9, ie at room temperatures of up to 27 °C measured above the server racks, with occasional periods of up to 200 hours per year at up to 30 °C, and up to a maximum temperature of 35 °C.⁷⁵ The maximum temperature of the room measured at high level above the server racks should not therefore exceed 28 °C. The minimum temperature of supply air should be 15 °C.

If a mechanical ventilation system is used the supply air should be filtered to prevent dust problems.

Server room cooling units should be sized on the sensible heat loads provided by the manufacturers of the equipment to be installed allowing for diversity or the actual measured power consumption of the equipment. It should not be necessary to provide more than 250 W/m². Typically the cooling duty will be in the range of 1.2 kW to 6 kW for Secondary Schools and 400 W to 1 kW for Primary Schools.

The design should consider the best method to minimise the ventilation and cooling required. For example, by locating server rooms on the north façade or in areas of the building where there are lower thermal gains and on an outside wall.

A ventilation opening to outside or locally controlled supply and extract ventilation should provide ventilation for occupancy and battery failure. This is needed for ICT staff who are servicing equipment in the server room; and for the safe operation of the batteries in UPS systems under fault conditions. Under fault conditions the batteries may release inflammable or corrosive gases. This is normally sulphur dioxide which has a very distinct odour of rotten eggs. Non-gassing valve regulated batteries do not off-gas except under fault conditions and should be specified for the UPS. Ventilation openings in the façade should be secure.

It may be economic to purchase new ICT equipment for the school where the potential savings on capital and running costs of the provision of mechanical cooling equipment provides the most cost effective solution. For example, purchasing up to date server equipment that can run at a higher temperature and therefore requires

⁷⁵ASHRAE TC 9.9 2011 'Thermal Guidelines for Data Processing Environments', published by the American Society of Heating, Refrigerating and Air-Conditioning Engineers (ASHRAE) gives guidance on temperature and humidity ranges according to the class of ICT equipment.

less cooling. The rationalisation of existing servers can reduce the number of servers required at any given time and as a result the amount of heat rejected.

An energy efficient ventilation system should minimise the hours of operation of any mechanical cooling provided. Cooling using outside air, high efficiency fans, and cross flow plate heat exchangers is the most energy efficient low carbon solution in the majority of UK locations. This requires server rooms and server cabinets to be located so that outside air can be ducted in to provide cooling.

Simple split type DX or VRF cooling systems may be needed for peak summertime periods to meet the temperatures specified in equipment warranties. However, for most of the year cooling using outside air is possible in the UK. This will have a higher capital cost but the payback period on energy running costs is short. Final selection of systems should be on a life cycle cost analysis. Evaporative cooling systems should not be used for schools as they can increase the risks associated with legionella and require a more onerous maintenance regime.

Heat from server rooms can also be used to heat adjoining parts of the building.

The position of the environmental control systems including any air conditioning units and the design of the server racks should enable effective cooling. There should be airflow through the server racks with no obstructions, ie ICT cabinets should be mesh fronted or simple frames with no doors or sides to allow good airflow. (This is normally called a warm and cold aisle system). Air conditioning units should be positioned for easy maintenance and units and their pipework should not be located above equipment cabinets in case of leakage. The condensate should be taken by gravity to the nearest drain outside the room.

6 Indoor and outdoor air quality

People typically spend 90% of their time indoors. Concern over human exposure to the pollutants found indoors, and their potentially adverse effects on the health, productivity, comfort and well-being of occupants, is growing. In busy urban areas, the overall exposure levels inside a building are likely to result from pollutants generated within and outside the building. So good indoor air quality depends on reducing pollutant ingress by design and operation of the building and the ventilation system and minimising the impact of indoor sources.

6.1 Indoor and outdoor air quality guidelines

WHO (WHO, 2010) has published health-based guidelines and recommendations for selected indoor air pollutants, which are known for their health hazards, and are often found in indoor environments, including school buildings.⁷⁶ WHO (2009) has also published guidelines for indoor air quality related to dampness and mould.⁷⁷

WHO (WHO, 2010) indoor air quality guidelines aim to provide a uniform basis for the protection of public health from adverse effects of indoor exposure to air pollution.

A wide range of pollutants generated outdoors are either known or suspected of adversely affecting human health and the environment. To address IAQ in schools it is necessary to consider the external air quality. The key urban pollutants are those covered by The Air Quality Standards Regulations 2010⁷⁸.

Table 6-1 presents the WHO indoor air quality guidelines and UK ambient air quality objectives. In addition to these there are HSE guidelines for wood and dust particles and fumes that apply to wood, metalwork and soldering activities. Workplace levels also apply to ash handling on biomass boiler plant. See section 6.5.3 on biomass boiler flues.

Approved Document F gives performance levels for indoor air quality in office-type accommodation. These performance levels are updated as appropriate in table 6-1

⁷⁶ World Health Organization (2010) WHO Guidelines for Indoor Air Quality: Selected pollutants. Copenhagen: WHO Regional Office for Europe online at the [WHO Regional Office for Europe website](#)

⁷⁷ World Health Organization (2009) WHO guidelines for indoor air quality: dampness and mould. Copenhagen: WHO Regional Office for Europe online at the [WHO Regional Office for Europe website](#)

⁷⁸ *The Air Quality Standards Regulations 2010 (SI 2010/1001)*. Available at: <http://www.legislation.gov.uk/ukxi/2010/1001/made>

to align with the World Health Organization (WHO, 2010) indoor air quality guidelines which should be used for schools.

For buildings with no other humidity requirements than human occupancy (eg offices, schools and residential buildings), humidification or dehumidification is usually not needed. Short-term exposure to very low or high humidity is not a problem.

AD F also sets a Total Volatile Organic Compounds (TVOC) limit of 300 $\mu\text{g}/\text{m}^3$ (8 hr).

EH40 Workplace exposure levels exist for many more chemicals than the other standards. They represent the highest acceptable limits for exposure of workers. Pollutant levels in science, design and technology, art and construction should always be kept below the levels given in EH40.⁷⁹

Indoor concentrations of radon are identified by measurement. Workplaces with high radon levels fall within the scope of the Ionising Radiations Regulations. See section 2.1.3.

⁷⁹ EH40/2005 "Workplace exposure limits"

Table 6-1 WHO IAQ guidelines and UK ambient air quality standards

Pollutants	WHO Indoor Air Quality Guidelines (2010) ⁸⁰	The Air Quality Standards Regulations 2010 ^{Error! Bookmark not defined.}
CO (mg/m ³)	100 (15 min)	
	60 (30 min)	
	30 (1 hr)	
	10 (8 hr)	10 (8 hr)
	7 (24 hr)	
NO ₂ (µg/m ³)	200 (1hr)	200 (1 hr) not to be exceeded more than 18 times a calendar year
	40 (1yr)	40 (1yr)
SO ₂ (µg/m ³)		350 (1 hr) not to be exceeded more than 24 times a calendar year
		125 (24 hr) not to be exceeded more than 3 times a year
PM ₁₀ (µg/m ³)		50 (24 hr) not to be exceeded more than 35 times a calendar year
		40 (1 yr)
PM _{2.5} (µg/m ³)		25 (1 yr)
Ozone (µg/m ³)		125 (8 hr) not to be exceeded on more than 25 days per calendar year averaged over three years
Radon (Bq/m ³)	No safe level	From Ionising Radiations Regulations not AQSR: 400 (approximately equal to annual average of 270)
	Reference level: 100	
	No more than: 300	
Benzene (µg/m ³)	No safe level	
		5 (1 yr)
Trichloroethylene (µg/m ³)	No safe level	

⁸⁰ WHO Indoor Air Quality Guidelines, 2010 online at the [WHO website](#)

Pollutants	WHO Indoor Air Quality Guidelines (2010) ⁸⁰	The Air Quality Standards Regulations 2010 ^{Error! Bookmark not defined.}
Tetrachloroethylene (µg/m ³)	250 (1yr)	
Formaldehyde (µg/m ³)	100 (30 min)	
Napthalene (µg/m ³)	10 (1yr)	
PAHs (ng/m ³ B[a]P)	No safe level	1 (total content in the PM ₁₀ fraction averaged over a calendar year)
Arsenic (ng/m ³)		6 (total content in the PM ₁₀ fraction averaged over a calendar year)
Cadmium (ng/m ³)		5 (total content in the PM ₁₀ fraction averaged over a calendar year)
Nickel (ng/m ³)		20 (total content in the PM ₁₀ fraction averaged over a calendar year)

Notes:

1yr: annual mean, 24hr: 24 hour mean, 1hr: 1 hour mean, 30 min: 30 minute mean
Conversion to ppm at 25 °C and 1 atmosphere: $X \text{ ppm} = (Y \text{ mg/m}^3)(24.45)/(\text{molecular weight})$

6.2 Indoor air pollutants

In line with the above guidelines, the SINPHONIE project proposed and used the pollutants that are presented in table 6-2, as indicators for IAQ.⁸¹

Table 6-2 SINPHONIE indicators for IAQ monitoring in European schools

Physical and chemical pollutants	Micro-biological pollutants
Benzene Trichloroethylene Tetrachloroethylene Formaldehyde Naphthalene Benzo(a)pyrene α-pinene d-limonene PM _{2.5}	Endotoxin Specific fungal and bacterial groups <ul style="list-style-type: none"> • Penicillium/Aspergillus group • Cladosporium herbarum • Aspergillus versicolor, • Alternaria alternate • Trichoderma viride • Streptomyces spp.

⁸¹ The SINPHONIE project (Kephalopoulos et al., 2014), 2014 guidelines and results are online at the [SINPHONIE website](#)

Physical and chemical pollutants	Micro-biological pollutants
PM ₁₀ NO ₂ Ozone CO Radon	<ul style="list-style-type: none"> • Mycobacterium spp. Allergens House-dust mites Horse, cat and dog allergens

The sources and health effects of the pollutants in table 6-3 are discussed in the SINPHONIE guidelines for schools and are presented in annex B.

In addition to table 6.3 and annex B, it should be noted that:

CO₂ – is an indicator of indoor air quality including odour. Exhaled air is usually the principal source of CO₂ in schools. CO₂ levels inside classrooms are affected by a number of factors including:

- the number of occupants in the room
- the activity levels of occupants
- the amount of time occupants spend in the room
- the ventilation rate

CO₂ levels from combustion may be particularly high in food cooking areas, science labs and technology areas when gas cookers or Bunsen burners are in use.

Odour – Odour is an indicator of poor air quality. It is emitted from people and from various materials that may be found in school buildings. Historically the level of outdoor air provided to a classroom was specified to avoid significant odour as perceived by persons entering the room. Occupants already in the room will not be aware of odour, as the olfactory sense rapidly adjusts to an odour. Odours can therefore build up to unpleasant levels and a sufficient outdoor air supply is needed to dilute and remove them.

Moisture/humidity - Activities such as cooking generate moisture. High humidity in spaces such as kitchens, bathrooms, gym areas and changing rooms can lead to moisture condensing on cold surfaces resulting in fabric decay and mould growth. Airborne fungi and dust mites can also be a problem. Dust mites, in particular, prefer moist warm conditions for survival and their droppings are known to cause allergic reactions in some people.

Volatile organic compounds (VOCs) – See annex B: Indoor air pollutants, sources and health effects for information on the VOCs in table 6-2. There is a wide range of organic compounds ranging from very volatile compounds (VVOCs) such as formaldehyde to semi-volatile compounds (SVOCs) such as phthalate plasticisers.

VOCs can present a risk to the health and comfort of occupants if concentrations in air exceed those known to cause adverse effects. Some are known to be toxic and can adversely affect children particularly those in vulnerable groups (for example, those that suffer asthma and allergies). At the levels found in school buildings their most likely health effect is short-term irritation of the eyes, nose, skin and respiratory tract. Odour generated by VOCs can also be a concern to the occupants. VOCs can be released from a wide range of construction, furnishing and consumer products used indoors (for example, surface finishes and paints); cleaning products; and also from markers, glues and paints used in art classes.

Common VOCs in schools include: formaldehyde, decane, butoxyethanol, isopentane, limonene, styrene, xylenes, perchloroethylene, methylene chloride and toluene.

Combustion gases – Burning of fuel for heating, hot water and for cooking releases potentially harmful gases such as carbon monoxide and nitrogen dioxide as well as particulates (including PM₁₀ and PM_{2.5} size fractions) and organic compounds. Hence the need for appropriate venting of fumes and regular maintenance of combustion appliances and associated means of ventilation.

Asbestos - Asbestos-containing materials (ACMs) are commonly found in schools built or refurbished before 1985. However, some asbestos-containing materials continued to be used up until 1999. If the materials are disturbed or become damaged, asbestos fibres may be released into the air and present a risk if inhaled. Some damaged ACMs can be made safe by repairing them and sealing or enclosing them to prevent further damage. Where ACMs cannot be easily repaired and protected, they should be removed by someone who is trained and competent to carry out the task. HSE guidance can help duty holders choose appropriate contractors to carry out this work. Further information on asbestos in school buildings is in the Asbestos Regulations, HSE guidance⁸² and DfE guidance on asbestos management for schools⁸³.

Radon – See section 2.1.3.1.

Water treatment chemicals – Swimming pools have two causes of pollutants. The water treatment chemicals themselves and the breakdown products resulting from the water treatment⁸⁴.

6.3 Sources of indoor pollutants

Pollutants in the indoor environment may originate from outdoor sources. The UK Air Quality Strategy (Volume 1) describes the main outdoor sources for each pollutant, and their potential effect on health and the environment. Pollutants emitted indoors come from, occupants and their activities, the building itself, cleaning materials and furnishings. The typical sources of indoor air pollutants are presented in table 6.3.

⁸² Health and Safety Executive (2000), Asbestos - An Important Message For Schools, online at [HSE asbestos FAQs for education](#)

⁸³ Online at [the DfE asbestos management in schools webpages](#)

⁸⁴ See references for a list of guidance on pools.

Table 6-3 Typical sources of indoor air pollutants in school buildings

Outdoor sources	Building equipment, components & furnishings	Other potential indoor sources
<p>Outdoor air pollution</p> <ul style="list-style-type: none"> • Pollen, dust, mould spores • Industrial emissions • Vehicle emissions • Agriculture and farms • Outdoor machinery emissions 	<p>HVAC equipment</p> <ul style="list-style-type: none"> • Mould growth in drip pans, ductwork, coils and humidifiers • Improper venting of combustion products • Dust or debris in plenums and ducts <p>Other equipment</p> <ul style="list-style-type: none"> • Emissions from office equipment (volatile organic compounds, ozone) • Emissions from workshop, lab and cleaning equipment 	<ul style="list-style-type: none"> • Science laboratory substances • Vocational art substances • Design and technology materials • Food preparation areas • Cleaning materials/air fresheners • Emissions from rubbish • Pesticides and weedkillers • Odours, PM (particulate matter) and VOCs from paint, mastics, adhesives, varnishes • Occupants with infectious diseases • Dry-erase markers and similar pens • Insects and other pests • Personal care products • Stored petrol and lawn and garden equipment • Combustion appliances for heating and cooking • Cleaners stores • Chemical stores • Battery rooms and UPS batteries in server rooms. See Section 5.15
<p>Nearby sources</p> <ul style="list-style-type: none"> • Loading bays • Odours from rubbish bins • Unsanitary debris or building exhausts near outdoor air intakes 	<p>Components</p> <ul style="list-style-type: none"> • Mould growth on or in soiled or water damaged materials • Dry drain traps that allow the passage of sewer gas • Materials containing VOCs (volatile organic compounds), inorganic compounds or damaged asbestos • Materials that produce particles(dust) or fibres 	
<p>Underground sources</p> <ul style="list-style-type: none"> • Radon • Pesticides • Leakage from underground storage tanks 	<p>Furnishings</p> <ul style="list-style-type: none"> • Emissions from new furnishings and floorings • Mould growth on or in soiled or water damaged furnishings 	

6.4 Minimising sources

6.4.1 Indoor source control

Potentially harmful emissions can be reduced by avoiding or eliminating sources of pollutants; for example, careful selection of materials and products can minimise VOC emissions. Reduction of VOCs is one of the most inexpensive of the BREEAM⁸⁵ credits to achieve.

Hygiene areas, toilets, shower areas, cleaners' rooms, areas holding soiled clothes or clinical waste and laundry should be mechanically ventilated and slightly negatively pressurised relative to adjacent spaces. This also assists odour control.

Recirculation of air contaminated by things other than from normal human activity (CO₂, moisture from exhalation, etc.) such as from kitchens and fume cupboards, should be prevented. See section 4.4.2 for guidance on location of exhaust outlets and section 5.7.7 on fume cupboard exhausts and building exhaust design guidance.

Extract outlets should be designed to avoid risk of unintentional recirculation into a supply inlet or natural ventilation opening. Extract systems or transfer arrangements should be designed to ensure there is a minimum possibility of back draughts from one area to another.

ASHRAE 62-1 gives air classifications that state where air can be drawn from. Access to ductwork for periodic cleaning should be provided. All exposed services should be designed to avoid collection of dust and contaminants and all services should be easy to access and clean.

Good practice is to use the smallest possible quantities of chemicals in experiments and other activities that involve hazardous chemicals. This is done to keep pollutant levels low. See CLEAPSS guidance for science⁸⁶.

The removal of pollution sources is a much more effective way to control indoor air quality than diluting the pollutant concentrations by ventilation. This may allow ventilation rates to be lowered, thus providing a potential saving in energy use.

The SINPHONIE guidelines provide an overview of regulatory and voluntary labelling schemes for low VOC (Volatile organic compound) emitting products in the EU (presented in table 6-4). They also provide guidance on eliminating chemical emissions from building materials and products. See annex C: Guidance on

⁸⁵ See BREEAM Technical Manuals for non-Domestic Buildings, available from <http://www.breeam.com/technical-standards>

⁸⁶ www.cleapss.org.uk

construction products and materials. There are currently no equivalent English or Welsh labelling schemes. However, a harmonised system of labelling of products according to performance with respect to emission to indoor air is being developed under the Construction Products Regulation No. 305/2011 (CPR, 2011⁸⁷). When available, products used during the construction or refurbishment of schools should be selected with harmonised labelling. In the absence of such a harmonised scheme, it is best to select products that have proven good emission performance according to a scheme shown in table 6-4.

Some construction products such as glass, stone and ceramics have low emissions because of their composition.

The EU directive 2004/42/CE21 gives some indication of emissions due to the VOC content of paints.

It is possible to test low solvent adhesives to demonstrate absence of carcinogenic and sensitising substances (BS EN 13999 Part 1:2006).

Construction and furnishing products containing formaldehyde (including formaldehyde containing resins) such as wood based boards should meet emission class E1 or equivalent (BS EN 13986:2004, BS EN 14080:2005, BS EN 14342:2013, BS EN 14041:2006, BS EN 13964:2004).

⁸⁷ Construction Products Regulation (CPR, 2011) Regulation (EU) No. 305/2011 of the European Parliament and of the Council of 9 March 2011 laying down harmonised conditions for the marketing of construction products and repealing Council Directive 89/106/EEC.

Table 6-4 Building materials, product labels on chemical emissions in EU

Building materials and products labels and guidance on chemical emissions in EU
<ul style="list-style-type: none">• European Ecolabel (e.g. textile-covered flooring, wooden flooring, mattresses, indoor and outdoor paints and varnishes: Europe), online at the European Ecolabel website• EMICODE® (adhesives, sealants, parquet varnishes and other construction products: Germany/Europe), online at the Emicode website• GUT (carpets: Germany/Europe), online at the GUT website• Blue Angel (Germany), online at the Blue Angel website• Nordic Swan (Scandinavia), online at the Nordic Swan Ecolabel website• Umweltzeichen (Austria), online at the Austrian Umweltzeichen website• AgBB (Specifications for construction products: Germany), online at the AgBB website• M1 (construction products: Finland),online at the rakennustieto Finland website• ANSES (formerly AFSSET) (construction products: France), online at the ANSES France website• CertiPUR (PU foam for furniture industry: Europe), online at the europur website• Ü mark (specifications in relation to CE marking: Germany), online at dibt.de• Danish Indoor Climate Label, online at teknologisk.dk• Swedish 'byggvarudeklaration' (construction products: Sweden, online at byggvarubedomningen.se• Natureplus (construction products: Germany/Europe, online at the natureplus website

Further information about control of emissions from construction products is available in BRE Digest 464 ⁸⁸, and information on source control to minimise dust mite allergens is available in BRE Report BR 417 ⁸⁹.

⁸⁸ BRE Digest 464: VOC Emissions from Building Products Parts 1 and 2; IP 12/03 VOC Emissions from Flooring Adhesives.

⁸⁹ Raw G. J., Aizlewood C. E. and Hamilton R. M. (2001) Building Regulation, Health and Safety. BRE Report 417. Online at the [BRE bookshop](#)

6.5 Outdoor air pollutants and sources

A wide range of pollutants generated outdoors are either known or suspected of adversely affecting human health and the environment. Key urban pollutants that need to be considered include those covered by the UK National Air Quality Strategy (NAQS)⁹⁰. These are presented in table 6-1. The description and main UK sources for each pollutant, as well as their potential effects on health/environment are discussed in the UK Air Quality Strategy (Volume 1).

London and major UK cities now require measures to tackle the problem of exposure of staff and students to frequent high air pollution while working and studying inside school buildings. The elevated air pollution levels close to some schools mean that designers must consider:

- the location of air intakes in unpolluted zones
- closing windows when external pollutant levels are high
- the use of air filtration units
- effective air filtration in ventilation systems

Air filtration is the most effective solution currently available to remove health damaging airborne pollutants and maintain clean indoor air for school buildings located in air pollution hotspots. Designers of ventilation systems for schools in areas of high pollution may therefore need to incorporate air filtration in such locations.

6.5.1 Minimising ingress of polluted outdoor air into buildings

In urban areas, there are a large number of different pollution sources. The sources are from varying upwind distances and heights, and occur over different timescales. This affects the level of internal contamination.

Internal contamination of buildings from outdoor pollution sources depends on:

- the pollutant dispersion processes around the buildings
- the concentrations of pollutants at the air inlets
- the ventilation strategy (natural, mixed-mode, mechanical)
- pollution depletion mechanisms
- the airtightness of the building (this affects the ingress of pollutants)

⁹⁰ Department of the Environment, Transport and the Regions, The Scottish Executive, the National Assembly for Wales and the Department of the Environment for Northern Ireland (2007). The Air Quality Strategy for England, Scotland, Wales and Northern Ireland. London: The Stationery Office ISBN 978-0-10-171692-5.

Further information can be found in Kukadia and Hall (2004)⁹¹.

The SINPHONIE guidelines⁹² recommend better control over the quality of the outdoor air that enters the school indoor environment.

In London, high NO₂ (nitrogen dioxide) concentrations have been measured at the kerbside and roadside monitoring stations⁹³. In many cases the NO₂ NAQS objective was exceeded. The greatest concentrations were over three times the NAQS objective. In the case of PM₁₀, there were only a few exceedances.

Where schools are located in polluted urban areas where pollutant levels exceed the maximum guideline levels in table 6-1, it is necessary to consider the best means to reduce the effects of high levels of outside pollution as part of the design of the ventilation systems.

The draft EN 13779⁹⁴ suggests the following starting points for Outdoor air classification (ODA 1 to 3) and Supply air classification (SUP 1 to 4):

ODA1 applies where the WHO (2005) guidelines and any National air quality standards or Regulations are fulfilled.

ODA2 applies where pollutant concentrations exceed the WHO guidelines or any National air quality standards or Regulations for outdoor air by a factor of up to 1.5.

ODA3 applies where pollutant concentrations exceed the WHO guidelines or any National air quality standards or Regulations for outdoor air by a factor over 1.5.

SUP 1 applies where the supply air fulfils the WHO (2005) guidelines limit values and any National air quality standards limit values or Regulations with a factor x 0.25

SUP 2 applies where the supply air fulfils the WHO (2005) guidelines limit values and any National air quality standards limit values or Regulations with a factor x 0.5

⁹¹ Kukadia V. and Hall D. J. (2004). Improving Air Quality in Urban Environments: Guidance for the Construction Industry. BR 474, Building Research Establishment. ISBN 1 86081 729 7

⁹² Kephelopoulos S., Csobod, E, Bruinen de Bruin Y, De Oliveira Fernandes E. Guidelines for healthy environments within European schools Co-published by the European Commission's Directorates General for Health and Consumers and Joint Research Centre, Luxembourg, 2014. ISBN 978-92-79-39151-4

⁹³ Fuller G, Mittal L. Air Quality in London – briefing note to GLA Environment and Health Committee July 2012, King's College London.

⁹⁴ BS EN 13779 standard is currently under revision (See prEN 16798-3 and prCEN/TR 16981-4).

SUP 3 applies where the supply air fulfils the WHO (2005) guidelines limit values and any National air quality standards limit values or Regulations with a factor $\times 0.75$

SUP 4 applies where the supply air fulfils the WHO (2005) guidelines limit values and any National air quality standards limit values or Regulations

Note: ODA1 is the least polluted outdoor air and SUP1 is the highest quality of supply air.

6.5.2 Filtration

Filtration provides a means of cleaning the supply air. Filtration also ensures that mechanical ventilation systems continue to operate at their optimum level by protecting fans and energy recovery devices. It is standard practice to fit filters to mechanical ventilation systems. CIBSE Guides A and B and BS EN 13779 provide recommendations on specifications for filters. The recommended filter classes from BS EN 13779 are given below in table 6.5. This standard is referenced in the UK National Calculation Method for Part L calculations and in the Euronorms for energy calculations for ventilation systems.

There are also other methods of cleaning air, such as air cleaners; electrostatic filters; culverts where pollutants drop out, absorbent materials or surfaces, and plants that absorb pollutants.

Ventilation system air-intake filters are usually used for particle removal. Activated carbon filters are required if it is necessary to remove gaseous pollutants. As filters for fine particles and gaseous pollutants are costly and difficult to maintain it is preferable to avoid the need for removal of fine particles and gaseous pollutants from outside air by effective positioning of air intakes and control of air ingress.

It is important that filters are replaced regularly to maintain good air quality. If filters are not maintained, they can become saturated leading to increased pollutant levels, potential microbial growth and odours.

Where filters are fitted a means should be provided to warn building operators when filters are dirty and need changing. This can be by means of an alert based on differential pressure sensors or hours run since last filter change at a local controller or a central BMS.

6.5.2.1 Filter classification

Table 6-5 Recommended minimum filter classes (from BS EN 13779)

Outside air quality				
	SUP 1	SUP 2	SUP 3	SUP 4
ODA 1	M5 + F7	F7	F7	F7
ODA 2	F7 + F7	M5 + F7	F7	F7
ODA 3	F7 + F9	F7 + F7	M5 + F7	F7

Table 6-5 shows the recommended minimum filter classes (as defined in BS EN 779: 2012) per filter section as recommended by BS EN 13779 for different outdoor air classes. Where it shows M5 + F7 filters this is a two stage particle filter system with M5 placed before the F7 filter.

The table advises on minimum final (or single) stage filtration classes, eg F7 or F9, but also in some cases advises on the pre-filter class M5 or F7. An F7 pre-filter should be a high capacity bag filter. This type of filter can be used in the pre-filter position (or as a single stage filter) because it has the capacity to handle the coarse particle size range.

The G, M and F filter ratings come from the European EN 779 classification system.

G stands for Coarse (Gross in German). Also known as Gravimetric which is the type of testing that applies to this class of filter. G3 or G4 class filters only have an efficiency of about 3% to 5% to remove fine particles such as those found in traffic emissions. They are not therefore effective in protecting people against exposure to traffic sourced air pollution.

F denotes Fine class filter for filtering out a high level of fine particles making it suitable for final stage filtration.

M stands for medium class filters, these filters were F class before 2012 but are now regarded as lacking the required fine particle removal efficiency to be used in final stage filtration. They will not make the supply air into buildings clean enough to breathe, without risk to health. This is especially the case in the range of airborne particles one micron diameter and below in size.

Table 6-5 air filters are selected to clean polluted air sufficiently so that it can be inhaled by school building occupants without risk to health. F7 is the lowest filter rating recommended to remove Particulate Matter (PMs) from traffic pollution.

Where the air is not polluted a G4 or M5 coarse filter will protect cross flow heat exchangers, as recommended by CIBSE Guide A, Table 1-5. However in this case,

according to table 6.5, it is more effective to use an M5 or F7 pre-filter upstream of the heat exchanger or coil, with a final stage filter at the end of the AHU before the supply air duct. This will keep it cleaner and better protect its heat transfer efficiency.

Many outdoor air guidelines refer to PM₁₀ (particulate matter with an aerodynamic diameter up to 10 µm). However, there is growing consensus that, for health protection, there should be greater emphasis on limiting smaller particles and to use as a criteria, particle concentration up to 2.5 µm (PM_{2.5}). The EU Healthvent study published in 2013 advises a minimum PM_{2.5} reduction of 50%. In polluted areas this is achieved by F7 class air filters.

For sites subject to traffic pollution BS EN 13779: 2007 recommends an air filtration efficiency of 80% (F9) for effective fine particle removal. The standard also recommends gas filtration using a carbon filter for removal of NO₂.

EN 779 is being replaced by a new filter test standard BS EN ISO 16890 -1: 2016: "Air filters for general ventilation: Part 1: Technical specifications, requirements and classification system based upon particulate matter efficiency (ePM)". This classifies filters according to their efficiency of removal of PM₁, PM_{2.5} and PM₁₀.

ePM₁ measures the efficiency of removing particles of size 0.3 to 1 µm in diameter, ePM_{2.5} from 0.3 to 2.5 µm and ePM₁₀ from 0.3 to 10 µm. There is an 18 month transition period for manufacturers to move from EN 779 filter test classifications to the new ePM classifications.

6.5.3 Biomass boiler flues

The World Health Organization has no lower acceptable safety limit for the key constituents of biomass combustion fumes. Storage of biomass also poses risks to health from carbon monoxide and methane build up from decay of biomass and from dust⁹⁵. The smell of storing biomass and the safe handling on site of biomass and ash should be considered. Workplace levels apply to ash handling on biomass boiler plant. See CIBSE AM15 Biomass Heating Application Manual, 2014.

Advice on chimney height design is given in IGEM UP 10 and in guidance on the Clean Air Act. Detailed design information is also given in LAQM.TG.(09)⁹⁶. Chimney height approval under the Clean Air Act is a separate application process from planning consent.

⁹⁵ HSE bulletin OPSD3-2012 'Risk of carbon monoxide release during storage of wood pellets, wood pellet safety bulletin, online at the hse.gov.uk website

⁹⁶ Local air quality management: Technical guidance LAQM.TG(09). Department for Environment, Food & Rural Affairs.

7 Thermal comfort

This section describes the thermal comfort criteria for the different spaces and activities in a school. It uses the comfort category descriptions from BS EN 15251, see table 7-1. Note that a space may have different comfort categories for different thermal comfort criteria. For example a sports hall has a category IV for cold draughts (see table 7-3) but a category III for the summertime overheating risk assessment (see table 7.9).

Standards for all aspects of thermal comfort are set out in BS EN ISO 15251⁹⁷. These are also the basis of the guidance in CIBSE Guide A, 2015. Thermal perception is influenced by many factors and is generally expressed in terms of whether people feel neither too hot nor too cold.

The standards for thermal comfort in BS EN 15251 during the heating season or when spaces are tempered, ie heated or cooled, are based on results of climate chamber studies. The standards were derived from analyses of the perception of a large sample of adults to their surrounding environment.

The thermal comfort criteria for schools in sections 7.2 to 7.6 are based on: the adaptive thermal comfort standards for free running buildings outside the heating season; PD CR 1752:1999; ISO 7730; and BS EN 15251. However the standards have been with modified to account for the needs of children and schools in the UK.

The methodology used in CR 1752, ISO 7730 and BS EN ISO 10551 relates the factors contributing to thermal comfort to predicted mean vote (PMV) and percentage people dissatisfied (PPD) indices.

The PMV and PPD indices predict the thermal comfort of people working in a reasonably steady state environment. They are the most widely used indices for conditioned buildings, in British, European, and International standards, especially where mechanical cooling is provided.

The PMV predicts the mean response of people within the same environment, and the PPD gives a quantitative measure of how many of these people would be dissatisfied with the comfort of the environment.

For comfort conditions for people with special requirements such as those with physical disabilities, BS EN ISO 7730 refers to ISO/TR 14415:2005, 4.2. Where pupils have special educational needs that affect their temperature response or for very young pupils an assessment of their particular needs will be required. Higher

⁹⁷ This document is based on the 2014 draft revision of EN 15251. See References.

categories of thermal comfort may be needed in particular areas of a school or across the whole school.

The main factors that influence thermal comfort are those which directly affect heat gain and loss.

Environmental factors are; air temperature, mean radiant temperature, air speed, location and direction of air movement, turbulence intensity, and relative humidity.

Personal factors are: physiological factors, psychological factors, clothing insulation level and metabolic rate (which is a function of age, body shape and activity).

Advice from an environmental engineer will be needed on thermal comfort issues regarding the building fabric and the heating and ventilation systems.

7.1 Thermal comfort criteria

BS EN 15251 thermal comfort criteria are based on the following categories.

Table 7-1 Categories of space or activity

Category	Explanation
I Equivalent to Category A of EN ISO 7730: 2005	High level of expectation. Also recommended for spaces occupied by very sensitive and fragile persons with special requirements like some disabilities, sick, very young children and elderly persons, to increase accessibility
II Equivalent to Category B of EN ISO 7730: 2005	Normal expectation
III Equivalent to Category C of EN ISO 7730: 2005	An acceptable moderate level of expectation
IV	Low level of expectation. This category should only be accepted for a limited part of the year

BS EN 15251 gives comfort criteria for both mechanically cooled buildings and for free running buildings. A free running building is defined as a building, with either natural or mechanical ventilation, which is not actively heated or cooled.

For refurbished buildings, the minimum standard is Category IV where Category III cannot be met for reasons of practicality and due to the extent of refurbishment. However, after refurbishment the criteria should not be worse than before refurbishment in any aspect affecting thermal comfort.

7.2 Operative temperature range

The operative temperature has replaced dry resultant temperature in CIBSE guides. It combines the effects of the air temperature and the mean radiant temperature within a limited range of air velocity and humidity.⁹⁸ Table 7-2 gives the recommended operative temperatures in the heating season.

A lower maintained operative temperature is often required outside the heating season in particular during hot weather. This may be necessary to take full advantage of night cooling and to prevent the heating system coming on unnecessarily before occupancy outside the heating season. In operation, supply air temperatures and space temperature set points may need to be adjusted seasonally to maintain thermal comfort throughout the year. See sections 4.8 and 4.13. Heating and ventilation system controls should therefore allow maintenance staff to adjust the internal space temperatures and supply air temperatures for each room to maintain a satisfactory level of comfort throughout the year.

In addition, there should be classroom-based temperature, ventilation and lighting controls, that are easy to understand and simple to operate by the teaching staff allowing them to change the conditions in the classroom during the course of the day.

The equation for simple model heat losses in CIBSE Guide A, section 5.8.1 can be used to determine the effect of heat emitter type on the thermal performance of a space.

⁹⁸ Mean radiant temperature is as defined in section 1.2.2 of CIBSE Guide A (2015 edition). Further information is available online at the [Healthy Heating webpage](#)

Table 7-2 Recommended operative temperatures during the heating season
measured at seated head height in the centre of the room

	Normal maintained operative temperature during the heating season - °C	Maximum operative temperature during the heating season at maximum occupancy - °C
Stores	5°C	N/A
Areas where there is a higher than normal level of physical activity (such as sports halls) and sleeping accommodation	17°C	23°C
Toilets, circulation spaces and store rooms that are normally occupied	17°C	24°C
Kitchen preparation areas	20°C	N/A
Spaces with normal level of activity, including teaching, study, exams, admin and staff areas, prep rooms, practical spaces, and computer suites	20°C	25°C
Spaces with less than normal level of activity or clothing, including sick, isolation rooms, changing rooms and gymnasia and dance and movement studios	21°C	26°C
Special schools and resourced provision, where needs of pupils tend to be complex and varied, including pupils with physical difficulties or profound and multiple learning difficulties.	23°C	25°C
Where pupils or adults may be wet and partially clothed for a significant length of time, such as swimming pools;	23°C in changing rooms and no more than 1°C above or below that of the water temperature in pool halls subject to a maximum of 30°C	28°C in changing rooms and no more than 1°C above that of the water temperature subject to a maximum of 30°C in pool halls
Where young children under 5 years old or those with physical disabilities may be wet or partially clothed for a significant length of time. More rapid air movement leads to greater chilling by evaporation and to compensate, a higher design temperature is required.	25°C The air speed in these environments should be as low as possible and not exceed 0.15 m/s at 25°C	30°C
Note: SEND pupils can be very sensitive to temperature and it may be necessary to adjust the normal operative temperature and maximum temperature in the heating season depending on the needs of the pupils.		

Seated head height should be taken as 1.1m above floor level for primary and 1.4m above floor level for secondary school classrooms.

7.3 Local thermal discomfort from draughts

ESFA has developed the following guidelines to avoid the cold draughts that often prevent windows from being opened in densely occupied classroom spaces with low-level air inlets.

7.3.1 Natural ventilation systems

The decision of whether or not natural ventilation is suitable should be based on the temperature difference on a cold still day during mid-season when the heating system is switched off. This assessment does not need to consider the velocity of the supply air plume but only its temperature. However, higher air speeds for summer daytime purge cooling of classrooms can be a nuisance if they blow papers off desks.

When the outside air temperature is 5°C, and the heat emitters are switched off the minimum air temperature of air delivered to the occupied zone at seated head height should be not more than 5 K below the normal maintained operative temperature given in table 7-2. Seated head height should be taken as 1.1m above floor level for primary and 1.4m above floor level for secondary school classrooms.

For Category I spaces the temperature difference should be less than 3°C whenever the natural ventilation system is in use.

The Window and damper draught calculator⁹⁹ can be used to estimate the temperature of the incoming plume of air from high level openings when it reaches the occupied zone. Alternatively measurements can be made in test rooms or CFD models can be used.

7.3.2 Forced draught systems

In a mechanical system where the driving force for the supply air is a fan, the design should meet the values in table 7-4 for the maximum temperature difference between the operative temperature of the room and the temperature of the supply air jet or plume and the maximum local air speed of the jet or plume for the different comfort categories for schools. This is based on the comfort criteria in BS EN 15251 for mechanical ventilation systems. The comfort categories for cold draughts for different spaces and activities given in table 7-3 should be used with table 7-4.

⁹⁹ The Window and damper draught calculator is available online on the DfE webpage on ventilation.

Table 7-3 Comfort categories for cold draughts

Space/Activity	Minimum recommended comfort category for draught
Stores, corridors and circulation spaces that are not normally occupied spaces,	N/A
Areas where there is a higher than normal level of physical activity (such as sports halls) and sleeping accommodation	Category IV. Low air speeds required for Badminton competitions may necessitate ventilation systems being switched off
Toilets, circulation spaces and store rooms that are normally occupied	Category IV
Kitchen preparation areas	N/A
Spaces with normal level of activity, teaching, study, exams, admin and staff areas, prep rooms, including practical spaces, and computer suites	Category II or III or Category IV where there is local manual control over the ventilation rate, eg manually opened windows or room ventilation with on/off and variable speed control
Spaces with less than normal level of activity or clothing, including sick, isolation rooms, changing rooms and gymnasias and dance and movement studios	Category II or III
Special schools and resourced provision, where needs of pupils tend to be complex and varied, including pupils with physical difficulties or profound and multiple learning difficulties.	Category I or II
Where pupils or adults may be wet and partially clothed for a significant length of time, such as swimming pools;	Category II
Where young children under 5 years old or those with SEN (Special education needs) or physical disabilities may be wet or partially clothed for a significant length of time. More rapid air movement leads to greater chilling by evaporation and to compensate, a higher design temperature is required.	Category I

Category IV should only be used in classrooms and other teaching spaces where there is local control over the room ventilation with variable speed control with override control by the teacher. The air quality criteria regarding CO2 levels must still be met.

Table 7-4 Draught criteria for mechanical ventilation systems

Recommended to provide thermal comfort

Category of space/activity	Draught criteria to provide thermal comfort			
	Winter		Summer and mid-season	
	ΔT (Min maintained operative temp - plume local air temp)	Maximum air velocity (m/s)	ΔT ($T_{\text{room, operative}}$ - plume local air temp) When $T_{\text{room}} \leq 25^{\circ}\text{C}$ or T_{comf}	Maximum air velocity (m/s)
I	1.5	0.15	1.5	0.15
II	2	0.2	2	0.2
III	3	0.25	3	0.25
IV	4	0.3	5	0.3

Table 7-4 assumes an activity level of 1.2 met, a clo value of 1.1 in winter 0.9 in mid-season and 0.7 in summer, and a minimum maintained operative temperature as in table 7-2 in winter and mid-season and 23°C in summer.

The values in table 7-4 apply to the supply air plume which delivers air to the occupied zone. The occupied zone should be taken as from 0.6 m to 1.4 m above floor level.

Higher speeds and larger temperature differences are permitted in winter for boost ventilation under the control of the teacher, eg in science or food technology.

For summertime cooling purposes, higher maximum air speeds are allowed and often preferable (draught becomes pleasurable breeze), but only under the condition that the teacher or the occupants have direct control over the openings or fans.

CFD (Computational fluid dynamics) modelling is not expected to estimate room air speeds. Manual calculations based on manufacturers information can be used to predict the speeds and they can be measured with an anemometer. Grille manufacturers supply the necessary tables to predict velocity at the occupied zone. Temperature will be based on the temperature of the jet and the appropriate entrainment coefficients. If required to measure air velocity, it should be measured with an omni-directional anemometer with a 0.2 s time constant.

The criteria for maximum local air speed and minimum local temperature of the supply air plume can be related mathematically by the method given in BS EN ISO 7730 to obtain a Predicted Mean Vote (PMV) that is related to PPD. This requires the clo value of the clothing and the metabolic rate of the occupants to be known. By using this formula, equivalent conditions to those given in table 7-4 can be obtained that give the same or a better PPD, eg a slightly higher air speed can be used with a slightly higher supply air temperature.

7.4 Radiant temperature difference

Surfaces of a room that have large temperature differences can cause discomfort, even when the air temperature is within acceptable limits. This can be due to cold or hot windows, walls or ceilings, direct sunlight, or poorly designed heating systems.

Varying surface temperatures influences the Radiant Temperature Asymmetry (RTA). In general, people are more sensitive to a warm ceiling than hot or cold vertical surfaces. For a warm ceiling, Radiant Temperature Asymmetry is defined in ISO 7730 as the difference between the Plane Radiant Temperatures measured in the upwards and downwards directions ($\Delta T_{pr, upwards}$). It is an indication of the effect on body core temperature of the asymmetry between floor and ceiling.

For rooms incorporating overhead radiant panels the designer should undertake calculations to determine the RTA within each space. In calculating the RTA, $\Delta T_{pr, upwards}$ can be assessed directly below a radiant panel or an array of panels using the formulae in BS 7726.

For a seated person, the difference in plane radiant temperature between the upper and lower parts of the space should be taken with respect to a small horizontal plane 0.6 m above floor level in accordance with CIBSE Guide A, (2015), section 1.6.6.4. For a standing person a small horizontal plane 1.1 m above floor level should be considered.

It is recommended that the RTA due to the presence of radiant panels overhead should not exceed 7 K.

This is particularly important when there is a sedentary occupation such as people sitting at a desk. Where there are vulnerable pupils, eg those with low mobility or difficulty in thermoregulation, the RTA should be reduced to 5 K.

Indicative minimum panel installation heights for a seated person are given below for a RTA of 7K and 5K. These tables are based on the seated person being positioned directly below the centre of a single overhead radiant panel in a typical classroom configuration.

Table 7-5 Radiant Temperature Asymmetry, RTA = 7K

Flow/Return Temperature (°C)	Assumed Emitter Temperature (°C)	Panel width (mm)				
		300	600	750	900	1200
		Minimum panel height above finished floor level (m)				
50/30	40	< 2.4	< 2.4	< 2.4	< 2.4	< 2.4
60/40	50	< 2.4	< 2.4	< 2.4	2.55	3.05
70/40	55	< 2.4	< 2.4	2.55	2.85	3.4
70/50	60	< 2.4	2.45	2.85	3.2	3.75
80/60	70	< 2.4	2.95	3.35	3.75	4.45
82/71	76.5	< 2.4	3.25	3.7	4.1	4.85

Table 7-6 Radiant Temperature Asymmetry, RTA = 5K

Flow/Return Temperature (°C)	Assumed Emitter Temperature (°C)	Panel width (mm)				
		300	600	750	900	1200
		Minimum panel height above finished floor level (m)				
50/30	40	< 2.4	< 2.4	< 2.4	< 2.4	2.85
60/40	50	< 2.4	2.5	2.85	3.2	3.8
70/40	55	< 2.4	2.8	3.2	3.55	4.2
70/50	60	< 2.4	3.1	3.55	3.95	4.65
80/60	70	< 2.4	3.65	4.15	4.6	5.4
82/71	76.5	2.6	4	4.55	5	5.85

The designer should consider:

- the mean water temperature, the size of radiant panels, and the available mounting height - mounting too low can result in complaints of excessive temperatures overhead - if mounted too high, occupants may not feel the full heating benefit
- the arrangement of radiant panels within the space - panels should be far enough apart to provide an even spread of heat and to prevent zones of intense heat
- the option of integrating luminaires and acoustic absorbers with radiant panels
- the layout and setting out of radiators taking account of the use of the space and location of occupants - hot water radiators have a lower radiant component than radiant panels, ie 10% to 20% radiant heat compared to 60% for a low temperature horizontal radiant panel - also as a greater RTA of 20 K is acceptable for a vertical surface such as a hot water radiator then the effect of a radiator on thermal comfort can be less than a horizontal radiant panel

Radiant panels should not be located above teaching walls or other areas where a teacher or student is likely to be standing for long periods of time. In this case, RTA calculations will need to show that the installation does not result in excess temperature differences.

The preferred layout of radiant panels may clash with the layout of lighting, sprinklers and other services. Also, for aesthetics, the radiant panels may be offset as part of the services coordination. In these cases the designer should assess the impact on RTA from offsetting the radiant panels.

To avoid discomfort and to conserve energy BS EN 15251 requires that, for a category III building, the vertical air temperature difference in the space during the heating season should be less than <2 K/m in the occupied zone. It will be necessary to limit the surface temperature of ceiling mounted radiant panels in classrooms or offices and in normal height teaching spaces to achieve this. Where radiant panels are used in high spaces over 4m in height measures should be taken to reduce stratification.

7.5 Underfloor heating

A floor that is too hot will cause thermal discomfort. The temperature of the floor, rather than the material of the floor covering, is the most important factor for foot thermal comfort. The BS EN ISO 7730 standard gives the allowable range of floor temperature for Category III as below 31°C. However, there are frequent complaints by school staff of swollen feet and tiredness from underfloor heating in schools. For this reason, the maximum recommended surface temperature has been reduced

from the values quoted in EN 15251. This is in line with the advice given in PD CR 1752 that floor temperatures higher than 26 °C should be avoided. This is particularly important where there are nursery-age pupils or pupils with complex health needs, where there is low activity and where pupils are likely to be sitting on the floor. In these cases, one solution is a self-regulating underfloor heating system set to 23°C to 24°C maximum surface temperature with a supplementary heating system.

The following categories apply to underfloor heating.

Table 7-7 Categories applying to underfloor heating

Type of space or activity	New Build Comfort category and maximum floor surface temperature	Refurbishment Comfort category and maximum floor surface temperature
Teaching and learning, drama, dance, exams, multi-purpose halls	II (<26 °C)	III (<29 °C)
Practical activities such as cooking	II (<26 °C)	III (<29 °C)
Sports Halls not used for exams	III (<29 °C)	IV (<31 °C)
Working areas, eg kitchens	IV (<31 °C)	IV (<31 °C)
Offices	II (<26 °C)	III (<29 °C)
Atria, circulation, reception and corridors - not continuously occupied	III (<29 °C)	IV (<31 °C)
Areas for pupils with complex health needs^a	I (<23 °C)	I (<23 °C)

^a In the case of pupils with complex health needs the temperature should be adjustable to cater for the needs of the pupils. In these cases an assessment of the individual needs must be made. This category applies only to Designated Units or Special Schools for non-ambulant pupils or those with medical conditions.

Underfloor heating should not be used where:

- the room use and heating profile will change quickly since underfloor heating is a slow response system (unless there is a supplementary fast response heating system)
- floors may be covered with mats, eg in soft play areas in Special Schools

- regular spillages can cause hygiene and odour problems, eg in toilets, changing rooms or hygiene rooms
- the positions of partition walls are likely to change
- fixings are required into the screed for furniture (eg lab benches) or equipment (eg in design and technology)
- there is bleacher seating

7.6 Performance standards for the avoidance of overheating

Overheating in classrooms and over-glazed larger spaces such as libraries and learning resource centres frequently occurs. This problem is often reported in post occupancy and staff surveys. DfE has adopted the adaptive thermal comfort method from BS EN 15251 to deal with this problem.¹⁰⁰ The adaptive comfort criteria only apply to free running buildings, ie those without mechanical cooling and with means for the occupants to locally alter conditions, ie to increase the ventilation rate by means of opening windows and by local room controls. Most schools are free running outside the heating season.

To manage overheating successfully using adaptive thermal comfort it is necessary to allow relaxation of formal dress in hot conditions. This encourages individual adaptation to conditions. Where pupils cannot regulate their temperature because of illness or physical disabilities special measures must be taken. They may need a more closely controlled thermal environment to help them to regulate their temperature, eg by providing local cooling for their specific needs. This advice should be given to schools and included in Building User Guides.

The personal factors identified which contribute to the perception of thermal comfort, cannot be directly influenced as part of the design. The provision of adequate ventilation for good indoor air quality and the perception of occupant control will together overcome some personal factors. Such factors as dress codes and activity schedules should be considered within the briefing process. They should be discussed with the client and school management team. This will help them to understand how they influence thermal comfort and to establish policies on such matters. The school will then be better able to reduce the risk and impact of overheating in their buildings.

All occupied spaces should be provided with ventilation for warmer weather, preferably by using, cross flow natural ventilation or ventilation systems with

¹⁰⁰ See also the guidance in CIBSE TM52 'The Limits of Thermal Comfort' (Technical Memorandum) and CIBSE KS16 'How to Manage Overheating in Buildings' (Knowledge Series)

equivalent ventilation effectiveness, and night cooling. This will minimise ventilation opening sizes and eliminate the need for mechanical cooling. Cross-ventilation strategies normally require smaller ventilation openings than for single-sided ventilation. This can reduce draughts and make it easier to meet the acoustic requirements for sound insulation of the building envelope.

Dynamic thermal modelling should be used to assess buildings for overheating and to size ventilation openings. The modelling should use the CIBSE DSY1 2020 (50th. percentile range) weather file most appropriate to the location of the school building.¹⁰¹

Mechanical ventilation should not be the sole method of summertime ventilation in occupied spaces, and there should be opening windows or vents, with sufficient effective opening area.

As a general rule, in the absence of detailed thermal modelling, openable windows or vents for summertime ventilation should be sized so that the effective area, A_{eff} is at least 3% of the floor area. (Note that depending on the type of opening, this can imply a physical opening area of ~5% of the floor area.) Some designs will result in more effective area than others and smaller effective areas may be possible if the design includes some degree of cross-ventilation, atrium-assisted stack ventilation or fan-assistance which will increase the airflow through openings. In all cases, the rooms need to have enough opening area and airflow to comply with the summertime overheating criteria below. See section 8.3 for definition of A_{eff} .

There are significant differences between the ventilation effectiveness of various types of windows or ventilation openings. See CIBSE AM 10 'Natural Ventilation in Non-Domestic Buildings' (Applications Manual) and section 8.3 on Ventilation opening areas.

Controls should be provided to enable the teacher to temporarily override the mechanical ventilation in each room to switch it on or off as required.

Where internal blinds are fitted to windows, these should not interfere with ventilation. Care should be taken to avoid flutter caused by ventilation airflow.

The design should allow air movement to be increased during the summer through opening windows or vents, switching on fans, or increasing the rate of mechanical ventilation. Ceiling fans may be used in higher spaces where they cannot be

¹⁰¹ See CIBSE Technical Briefing and Testing report on the new weather files online at [CIBSE](#)

reached, except in a Special School accommodating pupils who are visually sensitive to the movement or flickering reflections from such fans.

CIBSE has published criteria in TM 52 to assess overheating in free-running buildings, based on the adaptive comfort model. The DfE requirements set out in this section are based on these criteria.

This approach follows the methodology and recommendations of BS EN 15251 to determine whether a building will overheat, or in the case of an existing building whether it can be classed as overheating. The criteria are based on a variable temperature threshold that is related to the outside running-mean dry-bulb temperature, T_{rm} .

The designer should carry out an Overheating Risk Assessment (ORA) of free running designs by following the procedure set out in CIBSE TM 52. The design of mechanically cooled buildings should be in accordance with the CIBSE guidelines for air-conditioned buildings.

The designer should calculate the indoor operative temperatures for each of the months where the building is in free-running mode on a frequent (eg hourly or half-hourly) basis. The simulation tool used should be capable of calculating Operative Temperature, T_{op} and Running Mean Temperature, T_{op} and T_{rm} are defined in TM52. T_{rm} is a running mean of external air temperature and changes on a daily basis. Calculations should realistically account for the occupancy pattern of the building, heat loads of equipment, and the adaptive behaviour of the occupants. See section 8 for design criteria to be used in ORA calculations.

For all free-running school buildings, the ORA should be carried out based on the categories given in table 7-8.

Table 7-8 Adaptive thermal comfort category to apply

Type of space or activity	New Build	Refurbishment
Teaching and learning, drama, dance, exams, multi-purpose halls	II	III/IV
Practical activities such as cooking	N/A	N/A
Sports Halls not used for exams	III	IV
Working areas, eg kitchens	N/A	N/A
Offices	II	III/IV
Atria, circulation, reception and corridors - not continuously occupied	III	IV
Areas for pupils with complex health needs ^a	I	I

^a In the case of pupils with complex health needs an assessment of the individual needs must be made. Adaptive comfort thresholds may not be applicable and fixed temperature thresholds may need to be used. This category applies only to Designated Units or Special Schools for non-ambulant pupils or those with medical conditions. Local portable heating and cooling may need to be provided for SEN students with temperature sensitivities who are educated in mainstream accommodation.

The values for the maximum acceptable temperature (T_{max}) are calculated from the running mean of the outdoor temperature (T_{rm}) and the suggested acceptable range, as given in table 7.9 below, as follows:

$$T_{comf} = 0.33 T_{rm} + 18.8$$

and $T_{max} = T_{comf} + (\text{acceptable range } ^\circ\text{C})$

Therefore, for category II as defined in table 7.9, below, where the acceptable range is 3^oC:

$$T_{max} = 0.33 T_{rm} + 21.8 \text{ (See CIBSE KS16 or TM52 for definition of } T_{rm}\text{).}$$

Table 7-9 Categories for overheating risk assessment

and their associated acceptable temperature range for free running buildings (from BS EN 15251:2007, prEN 16789-1: 2015)

Category	Explanation	Suggested acceptable range °C
I	High level of expectation. Also recommended for spaces occupied by very sensitive and fragile persons with special requirements like some disabilities, sick, very young children and elderly persons, to increase accessibility.	+ 2 / - 3 °C
II	Normal expectation	+ 3/-4 °C
III	An acceptable moderate level of expectation	+4/-5 °C
IV	Low level of expectation. This category should only be accepted for a limited part of the year	>+4/ <-5 °C

The three criteria for overheating are all defined in terms of ΔT , the difference between the actual operative temperature in the room at any time (T_{op}) and T_{max} , the limiting maximum acceptable temperature. ΔT is calculated as

$$\Delta T = T_{op} - T_{max} (\text{°C})$$

ΔT is rounded to the nearest degree (ie for ΔT between 0.5 and 1.5 the value used is 1 °C, for 1.5 to 2.5 the value used is 2 °C and so on)

Three criteria have been developed which indicate when overheating is likely to be problematic. These criteria should be applied outside the heating season and for the hours of 09:00 to 16:00, Monday to Friday, from 1st May to 30th September, including the summer holiday period as if the school was occupied normally through the summer. A lunchbreak 12pm to 1pm with no internal heat gains during this period may be allowed for in classrooms. The three criteria are:

1. the number of hours for which an adaptive thermal comfort threshold temperature is exceeded (total hours of exceedance)
2. the degree to which the operative temperature exceeds the adaptive thermal comfort threshold temperature (daily weighted exceedance).
3. the maximum temperature experienced at any occupied time (upper limit temperature).

The first of these criteria (Criterion 1) defines a minimum requirement for the overheating risk assessment. The two additional criteria (Criterion 2 and Criterion 3) are primarily measures of short-term discomfort and should be reported for information only. If a school design fails to meet Criterion 2 or Criterion 3 then designers should consider potential overheating mitigation measures and indicate which are viable for the project. The use of these three performance criteria together aims to ensure that the design is not dictated by a single factor but by a combination of factors that will allow a degree of flexibility in the design.

Criterion 1 - Hours of Exceedance (H_e):

For schools, the number of hours (H_e) that ΔT is greater than or equal to one degree (K) during the period 1st May to 30th September for the defined hours inclusive shall not be more than 40 hours*.

* Note that when sports halls are used for exam purposes the duration for this activity shall be taken as weekdays 09:00 to 16:00 from 1st May to 8th July, with a lunchbreak 12pm to 1pm with no internal heat gains during this period. Criterion 1 should be calculated for this period with the number of hours reduced from 40 to 18.

An understanding of how often a building in any given location is likely to exceed its comfort range during the summer months (1st May- 30th September) can provide useful information about the building's thermal characteristics and potential risk of overheating over the range of weather conditions to which it will be subjected. Simple hours of exceedance are something that designers are familiar with and provide a good first assessment of acceptability. The defined hours used are the entire period from 1st May to 30th September for the defined hours of 09:00 to 16:00 excluding weekends. Full occupancy is assumed through the holiday period.

Criterion 2 – Daily Weighted Exceedance (W_e):

To allow for the severity of overheating the weighted Exceedance (W_e) shall be less than or equal to 6 in any one day.

Where $W_e = \sum h_e \times wf = (h_{e0} \times 0) + (h_{e1} \times 1) + (h_{e2} \times 2) + (h_{e3} \times 3)$

Where the weighting factor $wf = 0$ if $\Delta T \leq 0$, otherwise $wf = \Delta T$, and h_{ey} = time in hours when $wf = y$

This criterion sets an acceptable level for the severity of overheating, which is arguably more important than its frequency. It sets a daily limit of acceptability and is based on Method B – ‘Degree hours criteria’ in BS EN15251; 2007. It is the time (hours and part hours) during which the operative temperature exceeds the specified

range during the occupied hours, weighted by a factor. The weighting factor is a function depending on by how many degrees the range has been exceeded. The value of the weighting factor is based on the observed increase in the percentage of occupants voting 'warm' or 'hot' on the ASHRAE scale (overheating risk) with each degree increase in ΔT , the temperature above the comfort threshold temperature.

The value of 6 is an initial assessment of what constitutes an acceptable limit of overheating on any single day. This initial assessment was made from observations of the temperature profiles from case studies of a range of free-running buildings that are perceived to perform well at one end of the range and poorly at the other in regards to limiting overheating. For further information, see CIBSE TM 52.

Criterion 3 - Upper Limit Temperature (T_{upp}):

To set an absolute maximum value for the indoor operative temperature the value of ΔT shall not exceed 4K.

Criterion 3, the threshold or upper limit temperature sets a limit beyond which normal adaptive actions will be insufficient to restore personal comfort and the vast majority of occupants will complain of being 'too hot'. This criterion covers the extremes of hot weather conditions and future climate scenarios.

These criteria should be the basis of the thermal modelling of the building, with Criterion 1 defining the minimum requirement for assessing the risk of overheating of school designs.

In addition, the asymmetric radiation from hot ceilings in single storey teaching spaces should be less than 5 K in summertime. In order to achieve this hot air must not be trapped at ceiling level and there must be an adequate means to extract hot air from the ceiling zone. For example, cross-ventilation can provide adequate airflow across the ceiling and prevent a layer of hot air from building up beneath the ceiling.

Where, after consideration of such measures and taking account of other factors that could restrict the use of natural ventilation (eg air pollution, traffic noise) the designer deems that the heat load is such that cooling is required, the designer should consider low carbon cooling systems in preference to conventional air conditioning. Such systems could include using cool water from boreholes or drawing in air through earth tubes.

In most schools, it should not be necessary to use mechanical cooling in general teaching spaces with ICT equipment heat gains of less than 15 W/m² in classrooms, or 25 W/m² in practical spaces. Practical spaces are generally larger and have a lower occupancy gain per square metre than general teaching spaces. This helps to compensate for a higher equipment heat gain. Some practical spaces have high heat

loads, eg some graphics studios and music studios, which may have a high density of more powerful high-end computers.

Where the designer decides to use mechanical cooling, for example at times of peak summertime temperatures in areas of particularly high equipment heat load, this should be justified on heat load and energy efficiency grounds. For example, in teaching spaces where the heat gains exceed 25 W/m² mechanical cooling may be considered. See section 8.5.2 for further details on the calculation of internal heat gains.

7.7 Assessment of performance in use

Criteria used to assess performance in use of spaces should be easy for the facilities management team to monitor. Monitoring ensures that the designs achieve an acceptable standard of indoor air quality and thermal comfort in each teaching space over the year. This information should be fed back to the designers.

Air temperatures rather than operative temperatures should be used when communicating with the school and to assess thermal comfort in buildings in use, as these are easier for the occupants and the facilities management team to understand.

With modern building controls it is relatively easy to monitor the indoor environment by recording temperature and CO₂ as well as energy consumption. This can give the building occupants and facilities management team a greater knowledge and control over their environment.

Performance in use should be monitored in typical north, south, east and west facing classrooms and in other key spaces. Key spaces include atria, dining spaces, libraries, learning resource centres, admin and head teacher's offices, server rooms and reprographics rooms.

If there appears to be a failure then the contractor or a heating expert should be asked to consider the performance of the building. This may require investigation of operative temperatures and supply air temperatures and comparison with design predictions.

Results of monitoring of performance in use should be recorded as part of soft landings, Building Performance Evaluation and seasonal commissioning, See GDB Section 2.14.6: Building Performance Evaluation (BPE).

7.7.1 Performance in use standard for overheating

The following performance in use (PIU) criteria is recommended for use in contract specifications:

- It shall be possible to demonstrate within spaces that are occupied for more than 30 minutes at a time that, during the school day, the average internal air temperature does not exceed the average external air temperature measured over an occupied day by more than 5°C; both temperatures being averaged over the time period when the external air temperature is 20°C, or higher, except when the diurnal temperature range¹⁰² (lowest temperature from the previous night to the maximum daytime temperature the following day) is less than 4°C.
- The buildings shall be able to achieve temperatures within the acceptable range when windows, fans and ventilation systems are operated to reduce summertime temperatures, and the space has the intended number of occupants, numbers and types of computers, data projectors and other ICT equipment.
- Note: these overheating criteria are for the thermal comfort of occupants and are not applicable for equipment such as in server rooms. The extra heat loads from cookers in food and Bunsen burners in science that occur intermittently should be considered separately.

The intention is that the school notifies the contractor if a space fails the PIU criteria above and the internal recorded air temperatures exceed Cat III as defined in table 7-9. The contractor then examines temperature records and investigates whether or not the building is overheating and if the building is performing as designed.

To compare predicted design and measured temperatures it is necessary to measure operative temperatures as well as air temperatures. This can be done using a small black bulb thermometer or specialist electronic instrumentation. See CIBSE KS16 for further information.

It is recommended to inform the facilities management team that there may be a difference between the air temperature measured in the room and the design temperature (operative temperature). This can be explained in the Building User Guide.

¹⁰² The diurnal temperature is typically 7°C and is > 4°C on approximately 2/3rds of nights, i.e., except when there are anti-cyclonic conditions.

8 Design calculations for ventilation and thermal comfort

Ventilation and thermal comfort design for teaching and learning activities should be proved by modelling for the occupied period.

At the detail design stage it is desirable to use dynamic simulation tools particularly if ventilation is to be used for night cooling.

8.1 Internal conditions

The modelling assumptions affect the calculation results significantly. For this reason ESFA projects are required to use the following default assumptions regarding the internal conditions in the occupied spaces of the school:

- occupied hours assumed 09:00 to 16:00, Monday to Friday
- occupancy, lighting and small power set to zero during lunch hour (12:00 to 13:00) in all classroom areas
- the school is assumed to be occupied throughout the summer period for modelling of overheating - (this provides a degree of future proofing)
- An external ambient CO₂ concentration of 400ppm.

At the detail design stage for new buildings and major refurbishment or remodelling, dynamic thermal simulation tools should be used to assess ventilation, energy performance, summertime overheating and the effect of night cooling.

8.2 Ventilation calculations

CO₂ levels should be below the required values given in section 2.4. Calculations at concept design stage and scheme design stage need to be carried out for summer, winter and mid-season design conditions to prove that the design will operate satisfactorily throughout the year.¹⁰³

In addition to the ventilation design for normal teaching and learning activities the ventilation for specialist needs such as science or design and technology must be considered.

For a natural ventilation system the designer should follow the design steps given in CIBSE AM10.

¹⁰³ See CIBSE Guide A (2015) section 4.2 Ventilation and air quality including equations 4.1 and 4.2

Designs must provide sufficient openable areas in suitable locations for winter, mid-season and summer conditions; and means by which the occupants can control the openable areas must be provided. The designer should consider the results of the overheating analysis, which may show that higher airflow rates are required for either daytime or night time cooling.

8.3 Ventilation Opening Areas

There are two types of ventilation openings in the thermal envelope of a building, those that are intentional known as purpose provided openings (PPOs) and those that are unintentional known as adventitious openings.

Successful ventilation design requires the correct sizing and location of PPOs. In order to do this the effective area of the PPOs must be determined. The sizing of the PPOs is crucial to the ventilation performance of the building.

Unfortunately, not all standards and references use the same definitions of the effective area of a PPO at present and this leads to confusion and errors in sizing of PPOs. Numerous definitions of opening area are in use in smoke ventilation and natural ventilation texts, British and International standards and software tools. Some of these definitions currently contradict each other.

For clarity, BB101 adopts the definitions recommended by the CIBSE Natural Ventilation Group for free area, effective area and equivalent area¹⁰⁴. See annex D: Definition of opening areas.

For the avoidance of errors we recommend that design engineers should stipulate effective area, A_{eff} , on their drawings and ventilation specifications. Manufacturers should report A_{eff} as a matter of best practice to aid selection of the most appropriate PPO. The effective area of windows and ventilators is obtained by testing the appliances in accordance with BS EN 13141, 2004 and should be quoted by manufacturers. In the absence of empirical data from manufacturers, a calculation tool¹⁰⁵ can be used to estimate A_{eff} . It is necessary to use these tools with care and to consider clear opening dimensions rather than structural openings, taking into account reductions in opening dimensions due to frames, mullions, cills, reveals and adjacent windows.

¹⁰⁴ *A review of ventilation opening area terminology*, B.M.Jones, M.J.Cook, S.D.Fitzgerald, C.R.Iddon, Energy and Buildings 118 (2016) 249-258.

¹⁰⁵ see the Discharge Coefficient Calculator available on DfE website

For turbulent flow through a PPO as normally occurs in natural ventilation openings in buildings the airflow is governed by the following equation

$$Q = A_{eff} \sqrt{\frac{2\Delta P}{\rho}}$$

Q = turbulent uni-directional airflow rate (m^3/s)

A_{eff} = effective area of PPO (m^2)

ΔP = pressure drop across the opening (Pa)

ρ = density of the air (kg/m^3)

This equation applies where flow is fully turbulent and the coefficient of discharge, C_d , does not depend on the airflow velocity. Where this is not the case as in the case of a single PPO comprised of many small openings in parallel, eg an insect mesh, then caution is required and measurements are needed to establish the relationship between airflow rate and pressure difference.

For fully turbulent flow the effective area of a PPO, A_{eff} is defined as the product of its discharge coefficient and its free area:

$$A_{eff} = A_f \times C_d$$

A_f = Free area of the PPO (m^2), this is simply the physical size of the aperture of the ventilator and does not reflect the airflow performance of the ventilator.

C_d = Coefficient of discharge of the PPO, note that for windows this value changes dependent upon the opening angle and shape.

Some dynamic thermal modelling software use equivalent area, this term simply compares the PPO opening of effective area (A_{eff}) in question with an opening, which is circular and sharp-edged:

$$A_{eq} = \frac{A_{eff}}{C_{do}}$$

A_{eq} = Equivalent area (m^2)

C_{do} = Discharge coefficient of a sharp edged circular orifice, practitioners should check their software documentation for values of C_{do} used, these can vary between 0.60 and 0.65

The more complicated and/or contorted the airflow passages in a ventilator, the less air will flow through it.

If airflow occurs both into and out of a space through a single opening on one side of a building (bi-directional flow), the PPO coefficient of discharge will be reduced to

around 40% of the value for unidirectional flow, in part because only half of the ventilation opening is available for airflow into the building. This will impact on the effective area of the PPO. This is explained on pages 45 and 46 of CIBSE AM10 Natural Ventilation, 2005 where it states that in the buoyancy flow equation 4.12 the value of C_d is reduced typically from 0.6 to 0.25. Some software programmes already allow for this reduction in flow.

Obstructions to the flow of air (eg deep external sills and recesses) must be taken into account, as these will have the effect of reducing the airflow through the opening.

Examples of obstructions include sills, recesses and blinds. They can be seen as another airflow obstruction coefficient, and their presence means their impact on the PPO free area should be accounted for to achieve the required effective area.

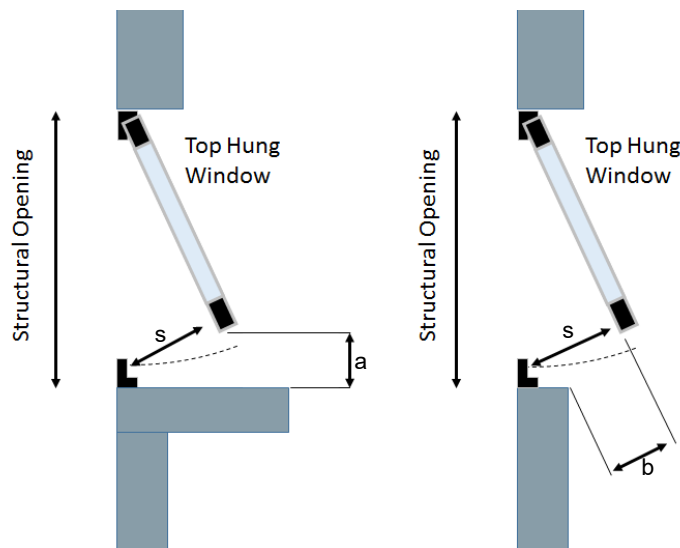

Figure 8-1 Example of ventilation area reduced by protrusion of window sill

In the example above top hung windows are opened by the same stroke length, s , but the protruding sill impacts on the free area because $a < b$

8.4 Mechanical ventilation

Where hybrid ventilation is being considered, the mechanical ventilation element needs to be modelled correctly. If it is supply and extract ventilation then a fixed or demand controlled ventilation rate of outside air can be incorporated in the model. If the system is extract only with openable windows, the model should be set up with a zone exhaust and not an exchange rate to outside. It should be noted that for thermal modelling and overheating assessment purposes mechanical ventilation is classified as 'free-running' in the absence of mechanical cooling and tight temperature control.

8.5 Thermal Comfort Calculations

8.5.1 Weather file for overheating risk assessment

CIBSE (Met Office) hourly weather data Test Reference Years (TRYs) and Design Summer Years (DSYs) are available for 14 locations across the UK.

The CIBSE DSY1 (50th percentile range) 2020 weather file most appropriate to the location of the school building should be used for the thermal comfort assessment. This does not necessarily mean the nearest location and the file should reflect the most compatible climatic characteristics.

DSY consists of a single continuous year of hourly data, selected from the 20-year data sets (1983 to 2004) to represent a year with a hot, but not extreme, summer. The selection is based on the daily mean dry-bulb temperatures during the period April - September, with the third hottest year being selected. This enables designers to simulate building performance during a year with a hot, but not extreme, summer.

8.5.2 Internal gains for overheating risk assessment

Occupancy rates vary depending on the activity present in the room. For a typical classroom 32 occupants should be allowed with each having a sensible heat gain of 70 W and a latent heat gain of 55 W (in primary school settings, a lower sensible heat gain of 60 W/pupil may be allowed).

Lighting gains in classrooms should be considered to be 7.2 W/m² unless calculations, eg of daylight displacement or product selection, show that lower gain rates are justified. These calculations must include all heat gains such as parasitic loads from dimmers and ballasts.

If daylighting is being used to lower the lighting gain, then this must be justified as being within the software's capability and that it has been properly implemented. If the blinds are included in the window transmission values then the lights should be assumed to be on.

ICT usage is dependent on the room type being investigated. Typically, a classroom will have a maximum ICT gain of 10 W/m², with dedicated ICT rooms and practical rooms with more powerful computers having up to 25 W/m². In some rooms, lower or higher equipment gains may be applicable. The ESFA ICT equipment heat gain

calculator can be used to estimate the heat gain from ICT equipment in teaching spaces. The calculator allows for the diversity of use and loads.¹⁰⁶

For the purposes of modelling summertime overheating to determine the required size of summertime natural ventilation openings to prevent summertime overheating the maximum average air speed through the vent should be assumed to be less than 0.8 m/s.

Food technology rooms should be modelled with the same internal heat loads as a standard classroom. The additional load associated with cookers should be assumed to be removed by extract hoods where they are fitted and in use.

Opening windows should be provided, preferably to provide cross-ventilation, to food technology, science rooms and other practical spaces to maximise air flow in summer peak conditions.

¹⁰⁶ See ICT equipment heat gain calculator on the ESFA ventilation webpage on www.gov.uk.

Annex A: Carbon dioxide levels in schools

Outside CO₂ concentrations are generally around 400 ppm. For a typical classroom with 30 students and 2 staff, an outdoor air ventilation rate of between 8 and 9 l/s/person corresponds to a carbon dioxide level of around 1000 ppm under steady state conditions depending on the ventilation system. See calculation method given in CIBSE Guide A.¹⁰⁷

The lowest ventilation rate of 8 l/s/person for schools is also proposed by the results of the HealthVent project¹⁰⁸. The project also recommended the “health-based reference minimum ventilation rate” of 4 l/s/person, when WHO indoor air quality (IAQ) guidelines are fully respected and the only pollutants are human bio-effluents (CO₂). Therefore, in reality, where the WHO guidelines are not met, rates higher than 4 l/s/person are needed, but after source control measures are implemented.

An outdoor air supply rate of 5 l/s/person corresponds to around 1500 ppm under steady state conditions.

Chatzidiakou et al. (2015) in their work within the Sinfonie project, concluded that simultaneous provision for limiting indoor CO₂ levels and thermal conditions below current guidelines (ie below 1000 ppm and 26 °C or 22 °C depending on season) can limit indoor airborne particulate matter concentrations below recommended annual WHO 2010 guidelines and may improve perceived IAQ.

According to European Standard EN 15251 – revision (EN16798-1 and -2), the CO₂ levels of 550, 800 and 1350 ppm above the outdoor concentration, correspond to Categories I; II; and III respectively for high; normal; and acceptable moderate levels of expectation, in terms of IAQ¹⁰⁹. Classification by CO₂ level is well established for occupied rooms, where CO₂ is mainly the product of human metabolism.

The recommended DfE design targets for CO₂ levels given in section 2.4 correspond to category II for ventilation with an allowance for category III for part of the time for natural and hybrid ventilation solutions.

The reason for the difference in design maximum target levels for CO₂ for the two types of system is that the variability of natural ventilation driving forces is much greater than that of a mechanical ventilation system.

¹⁰⁷ See CIBSE Guide A, 2015, section 4.2 ‘Ventilation and air quality’, equations 4.1 and 4.2

¹⁰⁸ Online at the [healthvent website](#)

¹⁰⁹ EN 13779 –revision (EN16798-3 and -4): Category I: High level of expectation and is recommended for spaces occupied by very sensitive and fragile persons with special requirements such as handicapped, sick, very young children and elderly persons; / Category II: Normal level of expectation;

Figure A-1 shows how the CO₂ levels achieved with demand controlled room-based mechanical ventilation vary.

With demand control of CO₂, mechanical system fan speeds accelerate rapidly with rising CO₂ levels, to stay within the allowable range for IAQ. When occupancy reduces during break times for example, fan speeds slow down within their turndown range, giving resultant power savings.

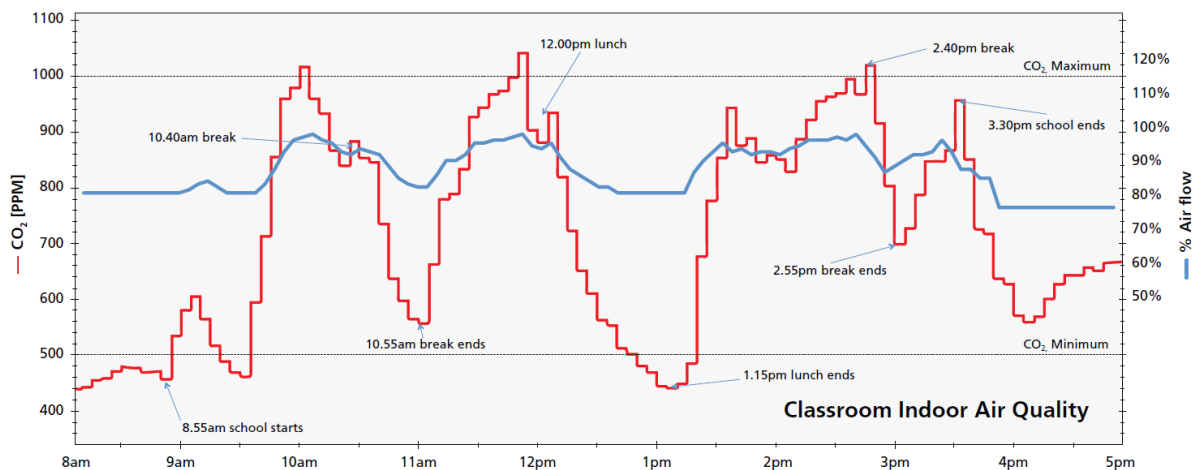

Figure A-1 Typical changes in CO₂ levels with demand control room-based mechanical ventilation systems, Graph provided by SAV Airmaster

Natural ventilation is much more variable than mechanical ventilation through the year due to changes in the driving forces caused by changing weather conditions. The wind effect varies and so does the stack or buoyancy effect whereas the maximum driving force from mechanical systems is a function of only the fan speed.

The graphs below show how CO₂ levels can vary over the course of a day in a naturally ventilated classroom with manually openable windows during the heating season and during the summertime. The graphs show typical weekly CO₂ traces from February and July from a secondary maths classroom in the north west of England. The red dashed line represents the average occupied CO₂ concentration. There are a number of reasons that explain the difference in CO₂ levels between February and July.

1. in July the vents are opened wider to deliver increased ventilation for cooling purposes resulting in much lower CO₂ concentrations.
2. occupants have been shown to be much more likely to open windows in response to high temperatures than in response to high CO₂ levels
3. cold draughts in winter make it much less likely that occupants will open the windows

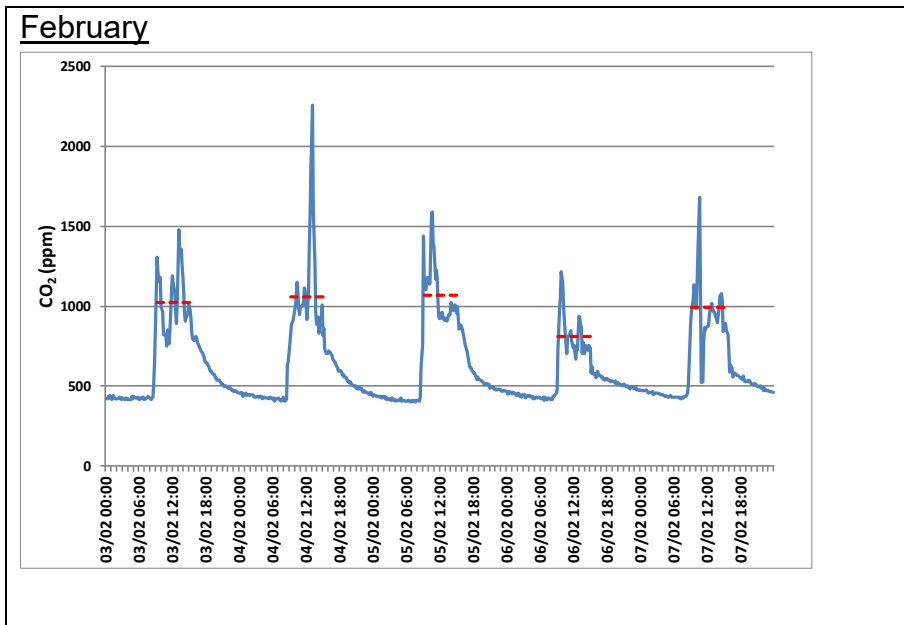

Figure A-2 Average occupied CO₂ concentration in February for a secondary maths classroom in a school in the North West of England. Graphs provided by SE Controls

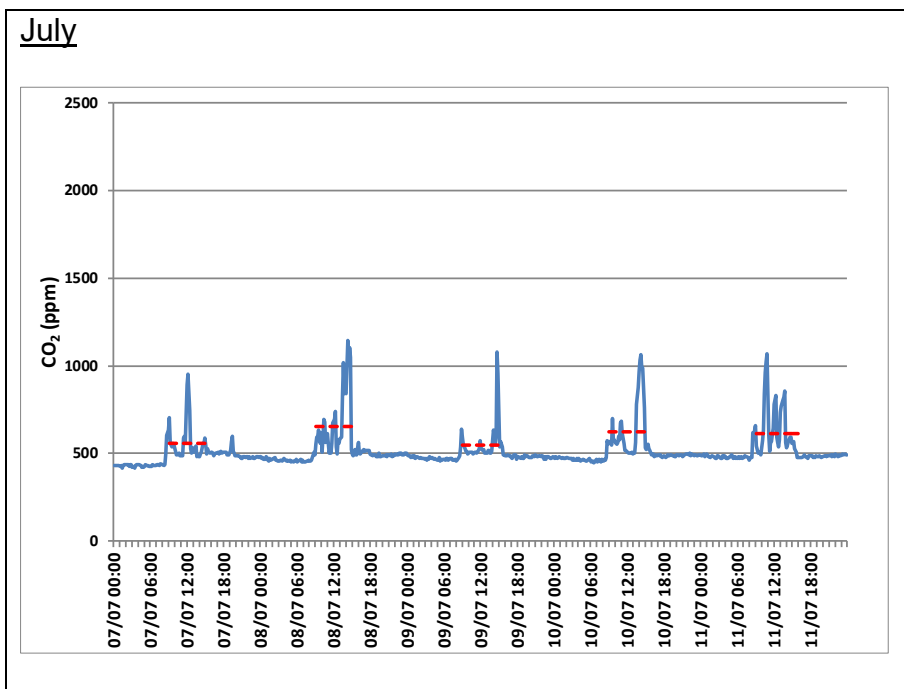

Figure A-3 Average occupied CO₂ concentration in July for a secondary maths classroom in a school in the North West of England. Graphs provided by SE Controls

The graphs in figure A-4 and figure A-5 show the amount of time during the occupied periods that the carbon dioxide level exceeds different CO₂ levels for two schools with fan-assisted pre-mixing natural ventilation systems that do not rely on ventilation from opening windows in wintertime. The schools were designed to the current CO₂

levels for a hybrid or natural ventilation system. This shows that in practice the current maximum design target CO₂ levels (1500ppm maximum target daily average) can achieve excellent air quality over the course of a winter or the whole year.

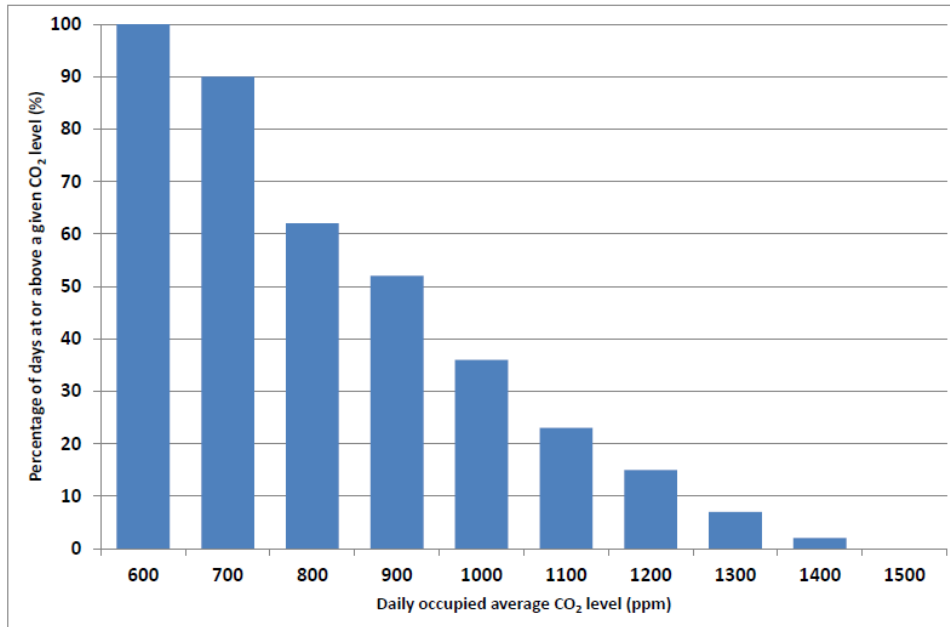

Figure A-4 A Secondary School all year CO₂ monitored results
Graph provided by Breathing Buildings

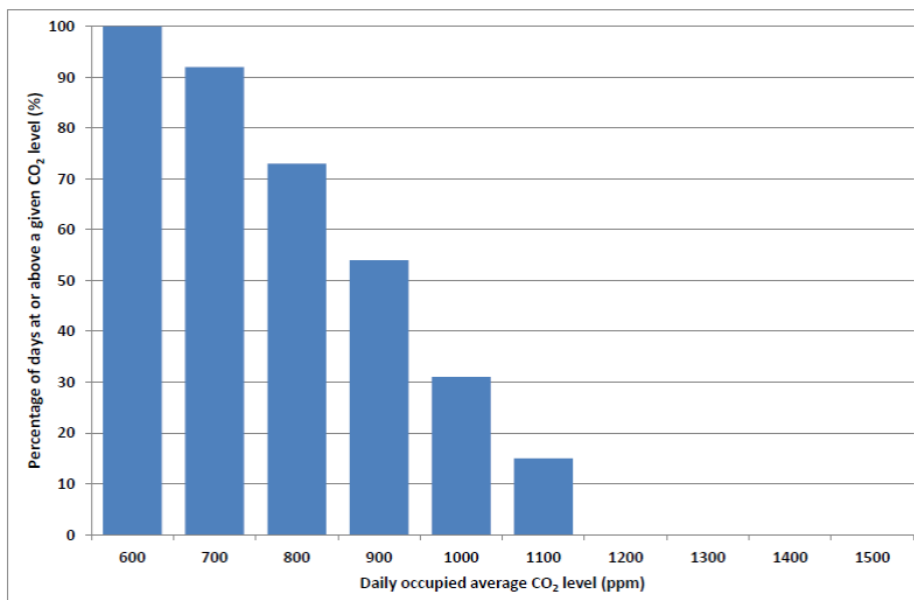

Figure A-5 Wintertime CO₂ levels monitored in a Preparatory School for age up to 13 years. Graph provided by Breathing Buildings

The elimination of cold draughts during wintertime and in mid-season conditions is a major design consideration for classroom ventilation systems. These spaces have relatively low ceilings and high flow rates are required because of the density of occupation. Many naturally ventilated schools that can achieve the air changes rates in winter do not because teaching staff do not open the windows during the cold weather. This is because the open windows would cause uncomfortable cold draughts.

If the maximum average design carbon dioxide level for natural ventilation systems was reduced to 1000ppm with a maximum of 1500ppm, as specified for mechanical ventilation systems, a much longer length of high level opening would be required to avoid cold draughts in winter. There is a practical limit to the length of this opening so that the cost of lowering the CO₂ target becomes increasingly expensive and impractical in the case of natural ventilation systems.

Hybrid systems are now the preferred choice in many schools for lower spaces such as classrooms. It is economic and practical to use demand controlled mechanical or fan-assisted systems for mid-season and wintertime and to use natural ventilation without cold draughts to complement the mechanical or fan-assisted ventilation in mid-season and for the peak summertime conditions. Windows can be used at most times of the year to supplement the mechanical or fan-assisted ventilation by opening the windows as far as possible without causing thermal discomfort with demand controlled mechanical or fan-assisted ventilation supplying the balance of the ventilation required. This leads to energy savings compared to a system using only windows for ventilation.

Providing summertime ventilation through a purely mechanical system requires very high flow rates for a classroom and exposed thermal mass. This is only recommended where the external noise level is very high or there is very severe pollution. Even in this case some manually openable windows or vents should be provided for occasional use.

In heavily polluted areas an alternative solution is to provide fan coil units for summertime cooling. Mechanical ventilation with fan coil units can have a low capital cost. However it is not well suited to most schools due to the complexity of the controls, the maintenance required and the high running cost.

In higher spaces, eg halls, where dumping of cold air from high-level windows or vents may not occur due to the height of the space, natural ventilation with or without mixing is often sufficient to meet the ventilation needs.

Annex B: Indoor air pollutants, sources and health effects¹¹⁰

Table B-0-1 Indoor air pollutants, sources and health effects

Pollutant	Sources	Health effects
Particulate matter (PM_{2.5} and PM₁₀)	<p>Outdoor combustion particles arise from:</p> <ul style="list-style-type: none"> ▪ industrial emissions ▪ road vehicle exhausts (diesel or petrol) ▪ non-road vehicles (eg marine, construction, agricultural and locomotive) ▪ heating exhausts (from coal or wood) ▪ forest fires ▪ other open fires or ▪ incineration (eg garden waste and burning rubbish) <p>The extent to which outdoor sourced particles affect indoor air depends on:</p> <ul style="list-style-type: none"> ▪ the building's location ▪ how close it is to the outdoor sources ▪ the main wind direction relative to the sources ▪ the type of ventilation system in use ▪ the proportion of outdoor air in the indoor air mixture ▪ the location of the air intakes 	<p>Epidemiological studies suggest that exposure to PM air pollution is associated with both short- and long-term health effects in humans.</p> <p>In particular, PM has been related to an increased risk of morbidity and mortality from cardiovascular diseases, lung disease, asthma, and other respiratory problems.</p> <p>Sub-populations, such as children, the elderly and people with respiratory diseases (eg chronic obstructive pulmonary disease, acute bronchitis, asthma, pneumonia), are at increased risk of health effects from PM exposure.</p> <p>Children are especially sensitive to air pollution because they breathe 50 % more air per kg of body weight than adults.</p> <p>PM_{2.5} poses the greatest health risk and can aggravate existing respiratory conditions, such as asthma and bronchitis. It has been directly associated with increased hospital admissions and emergency room visits for heart and lung disease, decreased lung function, and premature death.</p>

¹¹⁰ Based on table from the SINPHONIE project: Kephelopoulos et al., 2014

Pollutant	Sources	Health effects
	<p>Indoor combustion particulate sources include:</p> <ul style="list-style-type: none"> ▪ heating appliances ▪ dry process photocopying machines ▪ cooking appliances ▪ tobacco smoke 	<p>Short-term exposure may cause shortness of breath, eye and lung, irritation, nausea, light headedness, and possible allergy aggravations.</p> <p>Smoking is not permitted in schools.</p>
Benzene	<p>Benzene in indoor air comes from:</p> <ul style="list-style-type: none"> ▪ outdoor air (exhaust fumes from mobile sources) <p>and from indoor sources such as:</p> <ul style="list-style-type: none"> ▪ combustion (heating, cooking, incense burning, smoking, etc) ▪ attached garages ▪ building materials ▪ vinyl ▪ rubber and PVC floorings ▪ nylon carpets ▪ furniture and the storage of solvents <p>Benzene is currently not used in school science experiments.</p>	<p>Benzene causes central nervous system damage after acute exposure. Chronic benzene exposure may result in bone marrow depression. The major health risk associated with low level exposure to benzene is leukaemia and the strongest link in humans is with acute non-lymphocytic leukaemia (ANLL).</p> <p>The lowest level of exposure at which an increased incidence of ANLL among occupationally exposed workers has been reliably detected appears to be in the range of 32 to 80 mg/m³. The estimated unit risk of leukaemia per 1 µg/m³ is 6 × 10⁻⁶, and an excess lifetime risk of 1/10 000, 1/100 000 and 1/1000 000 are 17, 1.7 and 0.17 µg/m³, respectively.</p>
NO2	<p>The most important indoor sources of NO2 include:</p> <ul style="list-style-type: none"> • gas appliances ▪ kerosene heaters ▪ woodstoves ▪ fireplaces without flues 	<p>NO2 is an oxidising agent that is highly irritating to mucous membranes, and causes a wide variety of health effects. Most studies demonstrate substantial changes in pulmonary function in normal healthy adults at or above NO2 concentrations of 2ppm.</p> <p>Asthmatics appear to be responsive at about 0.5 ppm and subjective complaints have been reported at that level.</p>

Pollutant	Sources	Health effects
	<p>Ambient air (car exhausts) is a strong contributor to indoor concentrations of NO₂.</p> <p>The main ambient sources of nitrogen oxides (NO_x) include:</p> <ul style="list-style-type: none"> ▪ the intrusion of stratospheric NO_x ▪ bacterial and volcanic action ▪ lightning ▪ fossil fuel power stations ▪ motor vehicles <p>Domestic combustion appliances emit nitric oxide (NO), which is a reactive compound that is oxidised to NO₂.</p>	<p>NO₂ increases bronchial reactivity as measured by pharmacological bronchoconstrictor agents in normal and asthmatic subjects, even at levels that do not affect pulmonary function directly in the absence of a bronchoconstrictor.</p> <p>Epidemiological studies suggest that children who are exposed to combustion contaminants from gas stoves have higher rates of respiratory symptoms and illness than other children.</p> <p>There have been concerns that infants may be at a higher risk of symptoms of high indoor NO₂ levels because of their high respiratory rates in relation to body size and because they spend a large proportion of their time indoors.</p>
Formaldehyde	<p>Formaldehyde:</p> <ul style="list-style-type: none"> ▪ is released from most wood-based materials ▪ is used extensively as a preservative, disinfectant and biocide ▪ is a component of glues, varnishes, printing materials, textile treatments, permanent markers, automotive equipment, and dozens of other products ▪ is formed in combustion processes, tobacco smoking in particular <p>It is formed by the air chemistry of terpenes, which are contained in fragrances and air fresheners, and in particular as a product of the hydrolysis of formaldehyde based resins (mostly</p>	<p>Formaldehyde has a pungent odour and has irritating properties which cause discomfort.</p> <p>The symptoms displayed after short-term exposure to formaldehyde are: irritation of the eyes, nose and throat, together with exposure-dependent discomfort, lachrymation, sneezing, coughing, nausea and dyspnoea. Children have been reported to be more sensitive to formaldehyde exposure.</p> <p>In December 2012, the European harmonised classification and labelling system classified formaldehyde as a Category 1B carcinogen.</p> <p>Note: A Category 1 substance is known or presumed to have carcinogenic/mutagenic potential for humans. For category 1A, the assessment is based primarily on human evidence; for</p>

Pollutant	Sources	Health effects
	<p>urea formaldehyde, phenol formaldehyde, and melamine formaldehyde) resins.</p> <p>Because of its multitude of indoor sources, formaldehyde is found ubiquitously in almost all indoor environments at levels that exceed outdoor concentrations by an order of magnitude or more.</p> <p>Indoor concentrations of formaldehyde are influenced by temperature, humidity, ventilation rate, age of the building, product usage, presence of combustion sources, and the smoking habits of occupants.</p>	<p>category 1B, the assessment is based primarily on animal evidence.</p> <p>Smoking is not permitted in schools.</p>
<p>Naphthalene</p>	<p>Naphthalene is an intermediate in the production of phthalate plasticisers, synthetic resins, phthaleins, dyes, pharmaceuticals, preservatives, celluloid, lampblack, smokeless powder, anthraquinone, indigo, perylene, and hydronaphthalenes.</p> <p>Crystalline naphthalene is used as a moth repellent in mothballs and as a solid-block deodoriser for toilets.</p> <p>It is also used in the production of insecticides.</p> <p>Wood smoke, fuel oil and petrol also contain naphthalene.</p> <p>Naphthalene emissions into the atmosphere mainly originate from fugitive emissions and motor vehicle exhausts.</p> <p>Spills into land and water during the storage, transport and disposal of fuel oil and coal tar are lost and released to the atmosphere due to volatilisation, photolysis, adsorption, and biodegradation.</p>	<p>The main health concerns of exposure to naphthalene are respiratory tract lesions, including tumours in the upper respiratory tract.</p> <p>Based on the IARC classification, naphthalene is possibly carcinogenic to humans (Group 2B).</p> <p>Smoking is not permitted in schools.</p>

Pollutant	Sources	Health effects
	Usual indoor sources of naphthalene are unvented kerosene heaters and tobacco smoke.	
Carbon monoxide	<p>CO is widely generated indoors by unvented combustion appliances, particularly if they are operated in poorly ventilated rooms.</p> <p>Tobacco smoke is also an important source of indoor CO pollution.</p>	<p>Exposure to high levels of carbon monoxide is a frequent cause of fatal accidents. At lower levels, exposure leads to reduced exercise ability and increased risk of ischemic heart disease.</p> <p>Epidemiological studies involving large population groups, where exposures were generally at relatively low carbon monoxide levels, have demonstrated increased incidences of low birth weight, congenital defects, infant and adult mortality, cardiovascular admissions, congestive heart failure, stroke, asthma, tuberculosis and pneumonia (WHO 2010).</p> <p>Smoking is not permitted in schools</p>
Ozone	<p>Outdoors, particularly in urban settings near areas of high traffic, levels of ozone can become sufficiently elevated to cause health problems, particularly in sensitive individuals, such as elderly people or asthmatics. Since outdoor air is drawn into buildings through ventilation systems or open windows, elevated outdoor ozone levels can cause elevated levels indoors.</p> <p>A number of indoor sources can increase ozone levels even more and have been known to cause respiratory problems.</p> <p>The major indoor sources of ozone are:</p> <ul style="list-style-type: none"> ▪ office machinery (particularly electrical equipment) ▪ computer terminals ▪ laser printers 	<p>Being a strong oxidant, ozone can exert various physiological effects on pulmonary (lung) function, including reductions in lung function, air-exchange rates, and airway permeability.</p> <p>Ozone can also act as an irritant.</p> <p>The health impacts of exposure to elevated ozone levels include eye irritation, shortness of breath (dyspnoea), coughing, asthma, excessive mucous production, mucous membrane irritation, and chest pain upon inhalation.</p> <p>Subjects such as asthmatics and those with allergic rhinitis may be particularly susceptible to the effects of elevated ozone.</p>

Pollutant	Sources	Health effects
	<ul style="list-style-type: none"> ▪ photocopiers <p>Photocopiers are usually fitted with carbon filters to minimise emissions. However, without an effective maintenance regime, ozone concentrations can rise to unacceptably high levels.</p> <p>Ozone is sometimes used for swimming pool water treatment. High densities of such equipment and/or deficiencies in ventilation systems can lead to elevated ozone levels that may cause adverse health effects.</p>	
d-Limonene	<p>There is widespread use of d-Limonene in numerous consumer products used in indoor environments. It is the familiar lemon smell in many cleaning products and fragrances.</p>	<p>Potential hazards of exposure to d- Limonene are eye and airway irritation. Scientific findings suggest that reactions between unsaturated volatile compounds (eg limonene, α-pinene, styrene) and ozone or hydroxyl (OH) radicals produce chemically reactive products more likely to be responsible for eye and airway irritation than the chemically non-reactive VOCs usually measured indoors. It is therefore expected that an exacerbation of health effects will follow the concomitant presence of ozone in indoor environments.</p>
Trichloroethylene	<p>Consumers may be exposed to TCE by using:</p> <ul style="list-style-type: none"> ▪ wood stains ▪ varnishes ▪ finishes ▪ lubricants ▪ adhesives ▪ typewriter correction fluid ▪ paint removers 	<p>Exposure to TCE increases the risks of liver, kidney and testicular cancer as well as non-Hodgkin's lymphoma. Since there is sufficient evidence that TCE is a genotoxic carcinogen, all exposures indoors are considered relevant and no threshold can be determined.</p> <p>IARC has classified TCE as probably carcinogenic to humans (Group 2A) based on sufficient evidence in animals and limited evidence in humans.</p>

Pollutant	Sources	Health effects
	<ul style="list-style-type: none"> ▪ certain cleaners, where TCE is used as a solvent <p>Contaminated water or soil may also contribute to indoor pollution through TCE.</p>	
Tetrachloroethylene	<p>Consumer products that may contain TCA include:</p> <ul style="list-style-type: none"> ▪ adhesives ▪ fragrances ▪ spot removers ▪ stain removers ▪ fabric finishes ▪ water repellents ▪ wood cleaners ▪ motor vehicle cleaners ▪ dry-cleaned fabrics <p>Consumer products described above are sources of indoor TCA exposure.</p> <p>Contaminated drinking water may be a source of indoor TCA exposure when taking a shower or washing dishes.</p>	<p>Exposure to TCA can affect the central nervous system, eyes, kidney, liver, lungs, mucous membranes and skin.</p> <p>Carcinogenicity is not used as an end-point, since there are no indications that TCA is genotoxic and there is some uncertainty about the epidemiological evidence as well as the relevance of the animal carcinogenicity data to humans. However, because of the remaining uncertainty about the carcinogenicity of TCA, it should be kept under review.</p> <p>IARC concluded that there is evidence for consistently positive associations between exposure to TCA and the risks for oesophageal and cervical cancer and non-Hodgkin's lymphoma. TCA is classified by IARC as a Group 2A carcinogen (probably carcinogenic to humans).</p>
Radon	<p>The main source of indoor radon is the radon produced by the decay of naturally occurring radium in the soil subjacent to a building.</p>	<p>The most important route of exposure to radon and its decay products is inhalation.</p> <p>IARC classified it as a Group 1 human carcinogen in 1988, while the WHO considers it to be the second cause of lung cancer after cigarette smoking.</p>

Annex C: Guidance on construction products and materials

This annex is based on the SINPHONIE project. Due to increasing requirements for energy efficiency, it is necessary to use low-emission construction products and materials in school buildings.

This makes it possible to:

- control indoor air pollution and keep it at levels that minimise the associated risks to the health of school students and staff
- use ventilation to dilute unacceptable levels of indoor air pollutants

Significant effort is currently being put into designing sustainable school buildings.

This aims to:

- reduce the overall impact of the built environment on human health and the natural environment by ensuring the efficient use of energy, water and other resources
- protect the health of occupants
- improve educational outcomes
- reduce waste, pollution and environmental degradation

The choice of floor covering (wood or wood-based products, flexible and ceramic floor coverings) will depend on the intended use of the area and the necessary standard required. For example, ceramic floor coverings should be used anywhere where coverings must prove durable given constant, heavy use and frequent cleaning (eg toilets and changing rooms). Only floor coverings that can be damp wiped should be used in new or refurbished school buildings.

Textile floor coverings are not recommended because of the comparatively high cost of cleaning (in terms of time and money), and also their considerable contribution to the re-suspension of indoor particulate matter (PM).

Solvent-free, low-emission floor covering adhesives are preferable for all types of floor coverings (flexible floor coverings, carpets, parquet).

Only low-formaldehyde or formaldehyde-free eco-labelled furniture products should be used.

Before painting and varnishing, a check should be made as to whether the work requires the use of varnishes, or whether emulsion paints could be used instead. Emulsion and latex paints are suitable for mineral sub-surfaces (walls and ceilings).

Where possible low-solvent paints should be used but where there is a good reason to use a stronger solvent-based paint a considerable period of aeration and ventilation should be provided before occupation by staff and students.

Low-pollutant varnishes or wood glazes are the most suitable for protecting the surfaces of non-load-bearing timbers in indoor areas (classrooms, offices). Low pollutant varnishes to protect the surfaces of wooden components or objects exposed to the weather are also available on the market.

Surface-treating agents with a high solvent content should not be used for varnishing parquet. Water-based surface-treating agents (water seals) based on acrylic or polyurethane resin should be used instead.

Emulsion paints are suitable for covering large areas of walls, ceilings and façades. Only low-emission wall paints should be used in indoor areas (eg matt emulsion paints, silk gloss and gloss latex paints and silicate emulsion paints).

Preservatives included in the contents declaration on cans of water-based paints should be noted, to protect allergy sufferers.

Annex D: Definition of opening areas

A description of the geometry of an opening and its resistance to airflow are required so that the performance of a system can be established using a modelling tool. The vast majority of ventilation openings in buildings can be described as 'sharp-edged'. This means that they are thin when compared to their circumference. Figure D-1 shows a perfectly round hole in a thin sheet of metal, known as an orifice, with a thickness L (m). It is very easy to measure the diameter, d (m), of this opening and to identify it as 'sharp-edged' when $L/d < 2$. It is also easy to calculate its area, known as a 'free' area because it identifies the area free from obstruction.

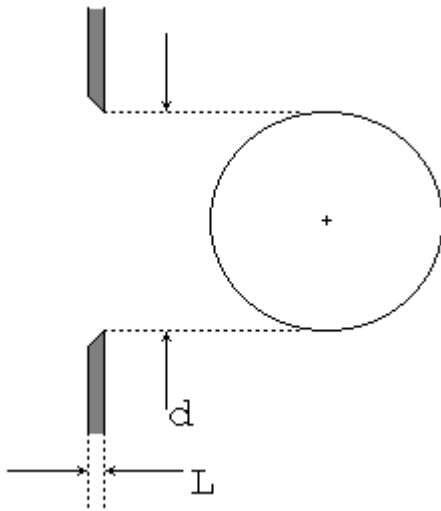

Figure D-1: A 'sharp-edged' orifice

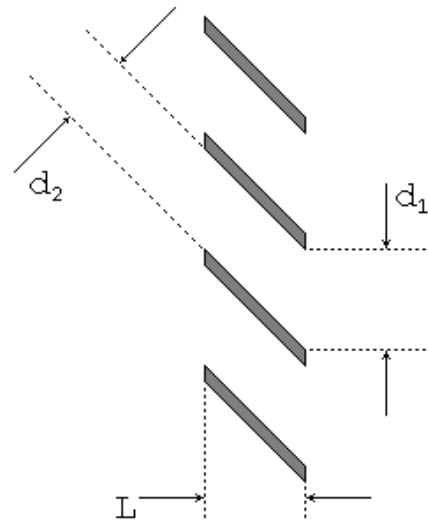

Figure D-2: Ambiguity in opening 'free' area

Figure D-2 shows a louvered opening where two possible lengths could be used to calculate a 'free' area and either can be correct so long as the appropriate equation is used and workings are clearly presented. However, this ambiguity makes a 'free' area a problematic metric because it has the potential to introduce error into the design process.

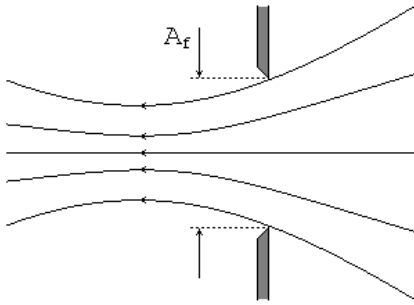

Figure D-3: Streamlines through a 'sharp-edged' orifice

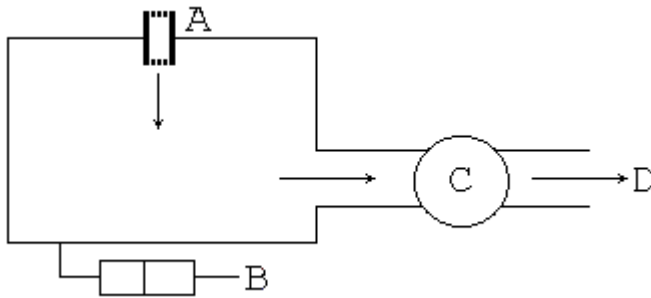

Figure D-4: Test chamber. A, ventilation opening; B, anemometer; C, flow meter, D, airflow to fan

For turbulent flow through an opening as normally occurs in natural ventilation openings in buildings the airflow is governed by the equation (1).

The airflow rate, Q (m^3/s), through any sharp-edged opening is proportional to its free area, A_f (m^2), the pressure drop across the opening ΔP (Pa), the density of the air ρ (kg/m^3), and the shape of the opening.

$$Q = C_d A_f \sqrt{\frac{2\Delta P}{\rho}} \quad (1)$$

Here, C_d is a dimensionless discharge coefficient that accounts for the constriction of streamlines after flow passes through an opening; see figure D-3. Accordingly, $0 < C_d < 1$ and a discharge coefficient, C_{d_o} , of the standard circular sharp-edged orifice shown in figure D-1 is often, but not always, given as $C_{d_o} = 0.61$.

For ‘sharp-edged’ openings with a fixed free area, such as a vent, the C_d can be considered constant in most cases. Then A_f and C_d can be combined into a single term, known as an ‘effective’ area, A_{eff} (m²) where

$$A_{eff} = C_d A_f. \quad (2)$$

Another approach is to calculate the ‘equivalent’ area, A_{eq} (m), of a hypothetical circular ‘sharp-edged’ orifice that allows air to pass at the same volume flow rate as a ventilation opening with area, A_f , at an identical pressure difference where

$$A_{eq} = \frac{C_d A_f}{C_{d_o}} = \frac{A_{eff}}{C_{d_o}}. \quad (3)$$

However, this process could introduce uncertainty into the value of A_{eq} because there is no standard value of C_{d_o} . Therefore, an ‘effective’ area, A_{eff} , is the most parsimonious metric that has the least uncertainty in its value and is the preferred unit of opening area. The area terms defined here agree with those given by Approved Document F.

The ‘effective’ area, A_{eff} , for a specific ventilation opening is measured using a standard test rig (see figure D-4) described by EN13141 Part 1. It comprises a sealed chamber to which an opening is attached, a fan, a long duct, and an anemometer. The A_{eff} is measured under still external air conditions with uniform density so that the airflow through the opening is exclusively generated by a fan. The flow rate, Q , is systematically varied and ΔP is recorded at each interval. A_{eff} is determined by regression using Equations (1) and (2).

Some ventilation openings, such as windows, have a variable A_f and so an indication of the change in A_{eff} with opening angle should be given. For longer openings that are not ‘sharp-edged’ (where $L/d > 2$), such as a stack, or for a *tortuous* opening that contains an insect mesh or an acoustic baffle, it is unlikely that A_{eff} can be considered constant over the operational range of pressure differences of the device (normally $\Delta P=0$ Pa to $\Delta P=10$ Pa) and so a manufacturer should be able to demonstrate any variation.

In the absence of empirical data, a calculation tool can be used to estimate A_{eff} (see the DfE website). The results will usually err on the side of caution and it is preferable for manufacturers to measure the effective area of ventilation openings.¹¹¹

¹¹¹ Jones BM, Cook MJ, Fitzgerald SD, Iddon CR. A Review of Ventilation Opening Area Terminology. Energy and Buildings. 2016;118:249-58.

References

1. Building Regulations Approved Documents (AD):
AD B – Fire Safety
AD C - Resistance to contaminants and moisture
AD F - Ventilation
AD J – Combustion appliances and fuel storage systems
AD K - Protection from falling, collision and impact, 2013,
ISBN: 978 1 85946 484 7
AD L – Conservation of fuel and power
Non-Domestic building Service Compliance Guide, ISBN 978 1 85946 535 6,
online at [gov.uk planning portal building regulations approved documents webpages](http://gov.uk/planning_portal/building_regulations_approved_documents/webpages)
2. BR211 – Radon: Guidance on protective measures for new buildings, 2015 edition. Available online at the [BRE bookshop](http://BREbookshop.com).
3. Building Bulletin 93, Acoustic Design of Schools: Performance Standards, Department for Education, 2015. Available online at gov.uk
4. Acoustics of Schools: a design guide, November 2015, the Institute of Acoustics (IOA) and the Association of Noise Consultants (ANC). Available from [ANC](http://ANC.org) or [IoA](http://IoA.org) websites.
5. COMEAP (2004). Guidance on the Effects on Health of Indoor Air Pollutants, Committee on the Medical Effects of Air Pollutants, Department of Health, December 2004.
6. Council Directive 99/30/EC of 22 April 1999 relating to limit values for sulphur dioxide, nitrogen dioxide and oxides of nitrogen, particulate matter and lead in ambient air.
7. BS EN 308: 1997, Heat exchangers. Test procedures for establishing the performance of air to air and flue gases heat recovery devices.
8. BS EN 13999-1:2013 Adhesives. Short term method for measuring the emission properties of low-solvent or solvent-free adhesives after application. General procedure.
9. BS EN 13986:2004+A1:2015 Wood-based panels for use in construction. Characteristics, evaluation of conformity and marking.
10. BS EN 13964:2004+A1:2006 Suspended ceilings. Requirements and test methods.
11. BS EN 14080:2013 Timber structures. Glued laminated timber and glued solid timber. Requirements.
12. BS EN 14342:2013 Wood flooring. Characteristics, evaluation of conformity and marking.
13. BS EN 14041:2004 Resilient, textile and laminate floor coverings. Essential characteristics.

14. EU Directive 2004/42/CE of the European Parliament and of the Council of 21 April 2004 on the limitation of emissions of volatile organic compounds due to the use of organic solvents in certain paints and varnishes and vehicle refinishing products and amending Directive 1999/13/EC.
15. IRR99 – Ionising Radiations Regulations HMSO London.
16. ISO 16000-6; 2011. Indoor air -- Part 6: Determination of volatile organic compounds in indoor and test chamber air by active sampling on Tenax TA sorbent, thermal desorption and gas chromatography using MS or MS-FID.
17. BS EN 779:2012, Particulate air filters for general ventilation – Determination of the filtration performance
18. BSEN 13779: 2007, Ventilation for non-residential buildings – Performance requirements for ventilation and room-conditioning systems. This standard is under revision and this document has been updated in line with the drafts: prEN 167983-3, 2014 and the associated Technical guidance in prCEN/TR 16798-4, 2014.
19. BS EN 15251: 2007, Indoor environmental input parameters for design and assessment of energy performance of buildings addressing indoor air quality, thermal environment, lighting and acoustics. This standard is under revision and this document has been updated in line with the drafts: prEN 167983-1, 2014 and the associated prCEN/TR 16798-2, 2014 which is a draft technical report giving guidance on the application of the revised standards.
20. BS EN 1886:2007 Ventilation for buildings – Air Handling Units – Mechanical performance
21. BS EN15780 Inspection of air filters, Air Handling Units and ducts
22. BS 4163 2014: Health and Safety for design and technology in educational and similar establishments – Code of practice.
23. BS EN 14037-1: 2003: Ceiling mounted radiant panels supplied with water at temperature below 120°C – Part 1: Technical specifications and requirements
24. BS EN 14037-2: 2003: Ceiling mounted radiant panels supplied with water at temperature below 120°C – Part 2: Test methods for thermal output
25. BS EN 14037-3: 2003: Ceiling mounted radiant panels supplied with water at temperature below 120°C – Part 3: Rating method and evaluation of radiant thermal output
26. BS EN 15377-1:2008 Heating systems in buildings – Design of embedded water based surface heating and cooling systems Part 1: Determination of the heating and cooling capacity
27. BS 7726: 2001: Ergonomics of the thermal environment: Instruments for measuring physical quantities.
28. PD CR 1752:1999, CEN Technical Report Ventilation for buildings – Design criteria for the indoor environment, BSI.
29. BS EN ISO 7730: 2005, Ergonomics of the thermal environment – Analytical determination and interpretation of thermal comfort using PMV and PPD indices and local thermal comfort criteria.

30. ISO/TS 14415:2005, 4.2 Ergonomics of the thermal environment – application of international standards to people with special requirements, such as those with physical disabilities
31. Human Thermal Environment, 3rd. Edition, Ken Parsons, 2014
32. A review of ventilation opening area terminology, B.M.Jones, M.J.Cook, S.D.Fitzgerald, C.R.Iddon, Energy and Buildings 118 (2016) 249-258, 2016

Health and Safety Executive (HSE)

33. HSG 258, Controlling airborne contaminants at work, A guide to local exhaust ventilation.
34. HSE L8, Legionnaires disease. The control of legionella bacteria in water systems.
35. EUROVENT 4-11

CIBSE

36. LG5, Lighting Guide 5, Lighting in Education, 2011, ISBN 9781906846176
37. AM10, Natural ventilation in non-domestic buildings, 2005, ISBN 9781903287569
38. AM13, Mixed Mode Ventilation, Applications Manual AM13, CIBSE (2000). Bookshop: ISBN 1 903287 01 4
39. AM15, Biomass Heating Application Manual, 2014
40. TM13, Minimising the Risk of Legionnaires' Disease, 2013
41. TM21, Minimising Pollution at Air Intakes, 1999, ISBN 0 900953 91 8
42. TM49, Design Summer Years for London, 2014
43. TM50, Energy Efficiency in Commercial Kitchens. 2009, ISBN 9781906846053
44. TM52, The Limits of Thermal Comfort: Avoiding Overheating in European Buildings, 2013, ISBN 978 1 906846 34 3
45. TM57, Integrated School Design, 2015, ISBN 978 1 906846 5 34, Guidance on how to approach the environmental design of educational buildings.
46. KS16, How to Manage Overheating in Buildings (CIBSE Knowledge Series 16), 2010, ISBN 978 1 906846 14 5
47. KS17, Indoor Air Quality and Ventilation (CIBSE Knowledge Series 17), 2011, ISBN 978 1 906846 19 0.

ASHRAE

48. ANSI/ASHRAE Standard 55 - 2013 Thermal Environmental Conditions for Human Occupancy.
49. ANSI/ASHRAE Standard 62.1 – 2013 Ventilation for Acceptable Indoor Air Quality

50. ANSI/ASHRAE Standard 62.1 – 2015 Supplement Addenda a, c, j, k, q, r and s, to 62.1 – 2013.

CLEAPSS documents: Design and Technology documents are available from <http://www.cleapss.org.uk/> and Science documents are available from <http://science.cleapss.org.uk/> [Not all documents are available to non-members]

51. CLEAPSS guidance L225 - LEV in Design and Technology (March 2003), available to CLEAPSS members only.

References on Fume Cupboards

52. G9a, Fume Cupboards in Schools, CLEAPSS, 2014, (Supersedes DfEE, Building Bulletin 88) available from [cleapss website](http://www.cleapss.org.uk/)
53. BS EN 14175, Fume cupboards. Type test methods
54. BS EN 14175-2:2003 Fume cupboards. Safety and performance requirements
55. BS EN 14175-3: Recommendations for the exchange of information and recommendations for installation
56. BS EN 14175 – 5.
57. ASHRAE Handbook - HVAC Applications, Chapter 45, Building Air Intake and Exhaust Design.
58. HSG 258, Controlling airborne contaminants at work, A guide to local exhaust ventilation.

References on swimming pools

59. Sports Council (1994), Small Public Indoor Pools.
60. Perrin GA, (1980), Sports Halls and Swimming Pools: A Design and Briefing Guide, ISBN 0 4191 1140 9, London: Spon
61. Swimming Pool Water: Treatment and Quality Standards: ISBN 0 951 7007 66, www.pwtag.org
62. Sports Council (1996), Handbook of Sports and Recreational Building Design, Volume 3: Ice rinks and swimming pools, Edited by Geraint John and Kit Campbell, 2nd Edition, ISBN 0-7506-2256-3, Oxford: Butterworth Heinemann
63. Publicly Available Specification PAS39:2003 Management of public swimming pools - Water treatment systems, water treatment plant and heating and ventilation systems - Code of practice. From 020 8896 9001 or orders@bsi-global.com

References on Local Exhaust Ventilation

64. Health and Safety Executive (1993), Introduction to Local Exhaust Ventilation, HS(G) 37, London: HSE Books. ISBN 0 11 882134 2 – online at the [HSE LEV webpage](http://www.hse.gov.uk/lev/)
65. Health and Safety Executive (1998), Maintenance, Examination and Testing of Local Exhaust Ventilation, HS(G) 54, London: HSE Books. ISBN 07176 1485 9

66. Health and Safety Executive (2003), COSHH Essentials Easy Steps to Control Health Risks from Chemicals, HS(G) 193 – on line at [the HSE COSHH Essentials webpage](#)
67. Industrial Ventilation: A Manual of Recommended Practice, 24th Edition, American Conference of Government Industrial Hygienists - www.acgih.org
68. British Standards Institute (2000), BS 4163, Health and Safety for Design and Technology in Schools and Similar Establishments – Code of Practice (AMD 11025), London: British Standards Institution Bookshop. Revision expected publication date September 2014.

References on Kitchen Ventilation

69. DW/172: Specification for Kitchen Ventilation Systems
70. DW/144: Specification for Sheet Metal Ductwork
71. BS 6173: Specification for installation and maintenance of gas-fired catering appliances for use in all types of catering establishments
72. BS 5440: Flueing and ventilation for gas appliances of rated input not exceeding 70 kW net
73. HSE Catering Information Sheet No 10: Ventilation in catering kitchens
74. HSE Catering Information Sheet No 23: Ventilation in catering kitchens
75. HSE L56: Gas safety (Installation and Use)
76. CIBSE TM 50: Energy Efficiency in Commercial Kitchens
77. IGEN UP11: Gas installations for educational establishments
78. IGEN UP19: Design, specification and application of interlock devices used within commercial and industrial applications including catering
79. CIBSE TM 42: Fan Application Guide.
80. Guidance on the Control of Odour and Noise from Commercial Kitchen Exhaust Systems, DEFRA, 2005
81. Reference on Food Technology rooms
82. BS 6172: Specification for installation, servicing and maintenance of domestic gas cooking appliances
83. BS EN 16282-2 – ‘Equipment for commercial kitchens - Components for ventilation of commercial kitchens - Part 2: Kitchen ventilation hoods; design and safety requirements’
84. BS EN 16282-3 – ‘Equipment for commercial kitchens - Components for ventilation in commercial kitchens - Part 3: Kitchen ventilation ceilings; Design and safety requirements’

B&ES (Building and Engineering Services association, formerly HVCA)

85. Specification for Kitchen Ventilation Systems, DW/172

86. TR19, Guide to Good Practice: Internal Cleanliness of Ventilation Systems, ISBN 0 903783 35 5, 2005
87. Specification for Sheet Metal Ductwork, DW/144

REHVA

88. Guidebook No.7, Low Temperature Heating and High Temperature Cooling, Jan Babiak, Bjaren W. Olesen, Dusan Petras, ISBN 2-9600468-6-2, 2007
89. Guidebook No.11, Air filtration in HVAC Systems, 2010
90. Guidebook No.12, How to integrate solar shading in sustainable building

BBSA (British Blind and Shutter Association)

91. Guide to Low Energy Shading, BBSA, 2015

© Crown copyright 2017

You may re-use this information (excluding logos) free of charge in any format or medium, under the terms of the Open Government Licence.

To view this licence,

visit <http://www.nationalarchives.gov.uk/doc/open-government-licence/> or e-mail: psi@nationalarchives.gsi.gov.uk.

Where we have identified any third party copyright information you will need to obtain permission from the copyright holders concerned.

This document is also available from our website gov.uk/esfa.